

# 2011 UPDATED CATALOG

CALL: 1-800-532-1932

COMING SOON !!!- TRY OUR  
WEBSITE AT: [allfordparts.com](http://allfordparts.com)  
E-mail: [allford@jps.net](mailto:allford@jps.net)

1909



1948

**POLICIES**

**TOLL FREE ORDER NUMBER: 1-800-532-1932**

- RETURNS** All items returned must be accompanied with a copy of the invoice. No returns on electrical items. Returns will not be accepted if the item has been altered, painted, primered or modified. No returns on special order or custom items. Returns after 30 days are subject to a 20% RESTOCKING FEE. No returns will be accepted after 6 months. Returns must be shipped pre-paid at owners expense. NO C.O.D.'s are accepted.
- CORES** Rebuilt or refurbished items will require a core or be charged a core charge prior to shipping. Core charges will be refunded when a rebuildable core is returned with a copy of the invoice. The core returned must be able to be rebuilt in order to receive a full refund. Cores that are damaged or rusted beyond repair will not be given a refund. All core returns must be shipped pre-paid at owners expense. No C.O.D.'s are accepted.
- DAMAGES - SHORTAGES** All claims for damages or shortages must be made within 48 hours of receiving your package. Claims on freight shipments must be made at time of receipt to the courier of the freight company before he leaves your business/residence. Please keep all packaing & cartons until claim has been completed. Please make driver note in system any visable damage of packaging to the driver at time of delivery.
- FOREIGN ORDERS** Payable in U.S. FUNDS only; by money order, bank check, or VISA/ DISCOVER/MASTERCARD (BEST & FASTEST). Please add 25% for shipping. There will be no backorders on foreign orders - please reorder.
- PRICE CHANGES** Due to unforeseen price increases from our suppliers, prices are subject to change without notice. Additional charges will be charged to your credit card or sent C.O.D.
- ORDERING** Phone, mail, fax or e-mail orders accepted. Please have all information available at time of order to help speed your order along. We accept VISA, MASTERCARD or DISCOVER, money orders and personal checks (may delay order). We also ship C.O.D. (Additional \$10 shipping). All items are shipped via Fed-Ex or USPS. Unless specified, all items that are temporarily out-of-stock will be backordered. Most backorders will be shipped within 1-3 weeks.
- SALES TAX** CALIFORNIA residents: Include sales tax rate of 7.5% for orders shipped. 8.5% over the counter.
- SHIPPING** Orders are primarily shipped by Fed-Ex or USPS. Items exceeding Fed-Ex weight or size limit will be shipped by truck freight or by Greyhound bus. (\$15 additional charge for orders shipped greyhound or freight requiring delivery to a depot or airport). Add \$10 for C.O.D. orders. Please specify if you would like a particular shipping method or delivery date/time. Shipping company is decided based on price, time-in-transit, & convience. Fed-Ex has a number of additional charges such as residential delivery, Rural delivery, and unusual & oversize pacakge. This will affect the final total of your shipping amount.

NEXT-DAY AIR, 2ND DAY AIR, 3RD DAY AVAILABLE AT ADDITIONAL COST

**Shipping Price Estimates:**

	<b>Mail</b>	<b>Priority Mail</b>			<b>FedEx</b>		
	Small under 1 lb	Flat Rate			Ground		
		Small	Medium	Large	Business	Resident	Rural-Residnt
<b>Minimum:</b>	\$2.75	\$6.00	\$11.50	\$15.20	\$6.64	\$9.83	\$12.73
<b>Average:</b>	\$3.50	\$6.00	\$11.50	\$15.20	\$9.60	\$12.02	\$15.55
	Small items only, no tracking	Parts must fit in flat rate size box. Insurance for \$50-\$250 add \$1. 2-3 est. delivery time.			Rural is for businesses/homes not in or near a major city. Average prices are estimates only. Large/Irregular shape items add \$8 and up.		

<b>Insurance Rates:</b>	\$100-\$500	\$1.00	\$500+	\$2.50 & up
-------------------------	-------------	--------	--------	-------------

**International:** International shipments primarily ship out USPS Priority Mail, we try to get you the cheapest rate possible. Please call or email you order and we can give you a rate quote for shipping.

\*Average is an estimate of our average order with no dimension exceeding 24" and under \$500.00. Larger orders are harder to estimate shipping amount. Running boards, bumpers, fenders, and other large items please call for shipping quotes.

# INDEX

FOR THIS CATALOG WE HAVE, FOR THE MOST PART, USED FORD'S ORIGINAL NUMBERING SYSTEM. BELOW WE HAVE LISTED THE GROUP, GROUP NUMBERS AND THE PAGES EACH GROUP OCCUPIES IN OUR CATALOG. A MORE SPECIFIC INDEX IS INCLUDED ON THE FOLLOWING PAGES FOR YOUR CONVENIENCE. IF YOU CAN'T FIND WHAT YOU NEED PLEASE INQUIRE!

<b>WHEELS, HUBS &amp; TIRES</b> 1000-1723 ..... 6 to 10	<b>RADIATOR</b> 8000-8499 ..... 43 to 51	<b>LAMPS</b> 13002-13799 ..... 74 to 83
<b>BRAKES</b> 2004-2666 ..... 11 to 15	<b>WATER PUMP</b> 8500-8599 ..... 49	<b>HORN</b> 13800-13899 ..... 85 & 86
<b>FRONT AXLE</b> 3010-3446 ..... 16 & 17	<b>FAN</b> 8600-8693 ..... 49 to 52	<b>WIRING</b> 14054-14621 ..... 66 TO 69, 87 & 88
<b>STEERING GEAR</b> 3503-3743 ..... 18 to 20	<b>FUEL TANK</b> 9001-9326 ..... 53 to 55	<b>ACCESSORIES</b> 15001-15709 ..... 89 to 91
<b>REAR AXLE</b> 4000-4906 ..... 21 to 23	<b>FUEL PUMP</b> 9270-9420 ..... 55 & 56	<b>FENDERS</b> 16000-16449 ..... 92 to 94
<b>FRAME &amp; BRACKETS</b> 5000-5149 ..... 25 & 26	<b>MANIFOLDS, CLAMPS, ETC.</b> 9421-9499 ..... 56	<b>RUNNING BOARD</b> 16450-16599 ..... 95 to 97
<b>BATTERY BRACKETS &amp; PARTS</b> 5150-5199 ..... 26 & 27	<b>CARBUREATOR</b> 9502-9685 ..... 56 & 57	<b>HOOD</b> 16600-16799 ..... 98 to 107
<b>MUFFLER &amp; EXHAUST PIPE</b> 5230-5293 ..... 27 & 28	<b>THROTTLE CONTROL</b> 9700-9828 ..... 56 to 61	<b>SPEEDOMETER</b> 17250-17499 ..... 109 & 110
<b>SPRINGS</b> 5300-5818 ..... 28 & 29	<b>GENERATOR &amp; BATTERY</b> 10000-10848 ..... 63-64	<b>WINDSHIELD WIPER</b> 17500-17674 ..... 110 to 113
<b>ENGINE</b> 6000-6928 ..... 31 to 36	<b>INSTRUMENTS</b> 10849-10899 ..... 54, 55, 64 & 109	<b>MIRRORS</b> 17679-17745 ..... 114 to 117
<b>TRANSMISSION</b> 7000-7449 ..... 37 to 40	<b>STARTER MOTOR</b> 11000-11516 ..... 65	<b>BUMPERS</b> 17750-17999 ..... 118 to 120
<b>CLUTCH</b> 7500-7646 ..... 40 & 41	<b>LIGHT SWITCH</b> 11648-11688 ..... 66	<b>SHOCK ABSORBER</b> 18000-18199 ..... 121
	<b>IGNITION</b> 12000-12425 ..... 70 to 72	<b>ACCESSORIES</b> 18400-18600 ..... 121 to 128
<hr/>		
<b>FASTENERS</b> ..... 129 to 135	<b>GLOVE BOX</b> ..... 154	<b>TRANSMISSION COVERS</b> ..... 178
<b>FLOOR SEALS</b> ..... 137, 138 & 172	<b>WINDOW CHANNEL</b> ..... 155 to 158	<b>FLOOR MATS</b> ..... 179
<b>COWL VENT</b> ..... 138	<b>DOOR SCUFF PLATES</b> ..... 159	<b>FIREWALL INSULATION</b> ..... 181
<b>BODY PATCH PANELS</b> ..... 139 & 140	<b>SUN VISORS</b> ..... 160	<b>WINDOW SEALS</b> ..... 152, 153 & 182 to 184
<b>DOOR HARDWARE</b> ..... 140 & 141	<b>WINDOW REGULATORS</b> ..... 161	<b>TRUNK</b> ..... 185 & 186
<b>WINDSHIELD FRAMES</b> ..... 142 to 144	<b>DOOR PULLS &amp; LOCKS</b> ..... 141, 162	<b>HANDLES &amp; CRANKS</b> ..... 83, 84, 187 to 193
<b>SHEET METAL</b> ..... 145 to 148, 227 to 228	<b>DOOR SEALS</b> ..... 163 & 164	<b>ESCUTCHEONS</b> ..... 191
<b>RUMBLE SEAT</b> ..... 149 & 150	<b>SEAT SPRINGS</b> ..... 165 to 168	<b>FIBERGLASS</b> ..... 194 to 204
<b>TOP IRONS</b> ..... 151	<b>STRIKER PLATES</b> ..... 140, 150 & 169	<b>DECALS</b> ..... 136
<b>CONVERTIBLE</b> ..... 152 to 154	<b>WOOD</b> ..... 170 to 172	<b>BOOKS</b> ..... 219 to 226
	<b>PICKUP</b> ..... 173 TO 177, 180	<b>STREET ROD</b> ..... 205 to 264

# INDEX

## A

A-ARMS ..... 247-249  
 ACCELERATOR PEDAL ..... 57  
 ACCESSORIES (STREET ROD) ..... 89-91, 121-124, 262,263  
 ADAPTERS (ENGINE TO TRANSMISSION) ..... 42  
 AIR CLEANER ..... 56, 211  
 ANTENNAS ..... 126  
 ANTI-SQUEAK PAD ..... 120  
 ANTI-ROLL BAR ..... 246,256  
 APRONS ..... 93  
 ARM RESTS ..... 169, 205  
 ASH TRAY KNOBS ..... 61  
 ASH TRAYS ..... 61  
 AXLE ASSEMBLIES (STREET ROD) ..... 245  
 AXLE BOLTS ..... 16  
 AXLE BUMPERS (FRONT) ..... 16  
 AXLE BUMPERS (REAR) ..... 29  
 AXLE - DROPPED ..... 245, 250

## B

BACK WINDOW FRAME ..... 151  
 BACK WINDOW RUBBER ..... 184  
 BACKUP LAMP SWITCH ..... 91  
 BATTERY ..... 64  
 BATTERY BOX ..... 26, 210, 262  
 BATTERY CABLES ..... 87  
 BATTERY CABLE BRACKETS ..... 87, 88  
 BATTERY DEFLECTOR ..... 26,178  
 BATTERY DISCONNECT SWITCH ..... 87  
 BATTERY HOLD DOWN FRAME ..... 26  
 BATTERY HOLD DOWN PAD ..... 26  
 BEAUTY RINGS ..... 7  
 BED FLOORING (WOOD) ..... 176  
 BED FLOORS ..... 174  
 BED STRIPS ..... 176  
 BELTS ..... 51  
 BELT BUCKLES & CAPS ..... 128  
 "BLACK BOX" ..... 207  
 BLUE DOT LENS ..... 81  
 BODIES STEEL (FIBERGLASS) ..... 146 (194)  
 BODY EMBLEMS ..... 94, 175, 178, 179, 213  
 BODY INSULATION ..... 181  
 BODY-TO-FRAME GUSSET ..... 178  
 BODY MOULDING CLIPS ..... 129  
 BODY MOULDINGS ..... 102, 107  
 BODY NUMBER PLATES ..... 124  
 BODY PANELS ..... 139, 140, 146-8  
 BODY PATCH PANELS ..... 139  
 BODY-TO-FRAME PADS ..... 25, 120  
 BODY SOCKETS ..... 134  
 BOLT KITS ..... 134, 135  
 BOOKS ..... 219 TO 226  
 BRAKE PARTS ..... 11 TO 15, 246-259  
 BRAKE COMPONENTS (STREET ROD) ..... 211, 246-259  
 BRAKE & CLUTCH PEDAL BUMPERS ..... 137  
 BRAKE & CLUTCH PEDAL PADS ..... 14, 262  
 BRAKE DRUMS ..... 8  
 BRAKE FLUID ..... 259  
 BRAKE HANDLE ..... 15, 259  
 BRAKE HOSE ..... 12, 259  
 BRAKE LINES ..... 13, 259  
 BRAKE LINING ..... 11  
 BRAKE PEDAL ASSEMBLIES ..... 211, 259  
 BRAKE RODS ..... 14  
 BRAS ..... 91  
 BUG SCREENS ..... 45  
 BUMPER PARTS ..... 119 TO 120  
 BUMPER BOLTS ..... 119  
 BUMPER BRACKETS ..... 118  
 BUMPER BRACKET GROMMETS ..... 120  
 BUMPER GUARDS ..... 119  
 BUMPER TIPS ..... 120  
 BUMPER-TO-BODY SEAL ..... 120  
 BUMPERS ..... 118  
 BUMPERS (DOOR) ..... 158

## C

CAMSHAFT ..... 33  
 CAMSHAFT BEARINGS ..... 34  
 CAPS ..... 124  
 CARBURETOR ..... 56, 57  
 CAR COVERS ..... 91  
 CHASSIS - STREET ROD ..... 234-243  
 CHOKE RODS ..... 56  
 CHOKE ROD & CABLE KITS ..... 62  
 CHASSIS AND FRAMES ..... 233-243  
 CHASSIS COMPONENTS ..... 246-262  
 CHASSIS (PRO-COMP) ..... 242, 243  
 CIGAR LIGHTERS ..... 90, 108  
 CIRCUIT BREAKER ..... 71  
 CLOCK ASSEMBLY ..... 89  
 CLEVICE ..... 264  
 CLOCK BEZEL ..... 60  
 CLOCK FACE ..... 89  
 CLOCK KNOB ..... 89  
 CLOCK LIGHT WIRE ..... 66, 89  
 CLOCK MIRRORS ..... 115

CLOCK PANELS ..... 60  
 CLUTCH PARTS ..... 40, 41  
 COLUMBIA REPAIR KIT ..... 22  
 COLUMBIA DECAL ..... 225  
 COLUMBIA KNOBS ..... 153  
 COLUMBIA INSTRUCTIONS ..... 225  
 COIL ..... 70  
 COIL-OVERS ..... 247, 248, 251, 255  
 CONDENSERS ..... 71  
 CONDENSER BOOT ..... 71  
 CONNECTING RODS ..... 33  
 CONVERTIBLE DOOR BUMPER KIT ..... 158  
 CONVERTIBLE HEADER BRACKET ..... 151  
 CONVERTIBLE RUBBER ..... 152, 153  
 CONVERTIBLE TOP IRONS ..... 151, 204  
 CONVERTIBLE TOP PARTS ..... 151 TO 154, 204  
 CONVERTIBLE WINDOW CHANNEL ..... 152  
 COMPRESSOR, AIR CONDITIONING ..... 207  
 COOLING SYSTEM ..... 43 TO 52  
 COOLING SYSTEM (STREET ROD) ..... 260  
 COWL-TO-FENDER SEAL ..... 93  
 COWL-TO-FIREWALL SEAL ..... 138  
 COWL LACING ..... 104  
 COWL LAMPS ..... 77, 78  
 COWL LAMP LENS ..... 78  
 COWL LAMP PADS ..... 78  
 COWL MIRRORS ..... 116  
 COWL MOULDINGS ..... 107  
 COWL PATCH PANELS ..... 139  
 COWL TRIM ..... 107  
 COWL VENT GASKET ..... 138  
 COWL VENT HANDLE ..... 138  
 COWL VENT HINGE ..... 138  
 COWL VENT KNOBS ..... 59  
 COWL VENT LID ..... 138, 201  
 COWL VENT PARTS ..... 138, 139, 201  
 COWL VENT RATCHET ..... 138  
 COWL VENT SCREEN ..... 138  
 CRANK HOLE COVER ..... 47  
 CRANKING TOOL ..... 109  
 CRANKSHAFT GEAR ..... 34  
 CROSSMEMBERS (STREET ROD) ..... 212, 246, 248, 255, 261  
 CROSSOVER PIPE ..... 27  
 CURTAIN ROD SOCKET ..... 134  
 CUT-OUT SWITCH ..... 63  
 CYLINDER HEAD ..... 31, 42  
 CYLINDER HEAD HARDWARE ..... 31, 32  
 CYLINDER SLEEVE ..... 31

## D

DASH GROMMETS ..... 57  
 DASH INSULATORS ..... 181  
 DASH KNOBS ..... 58, 59, 61, 108, 123  
 DASH PANELS ..... 60-62, 108  
 DASH PLASTIC ..... 60, 61  
 DASH SWITCH (DIMMER) ..... 84  
 DASH TRIM ..... 60  
 DATA PATENT PLATES ..... 124  
 DECALS ..... 136, 225  
 DECK EMBLEM ..... 83  
 DECK PANEL ..... 95, 147, 148, 203  
 DECK LID BUMPER ..... 185  
 DECK LID HANDLE ..... 83, 84  
 DECK LID HANDLE BASE ..... 84  
 DECK LID HANDLE PAD ..... 84  
 DECK LID HINGE ..... 186  
 DECK LID LATCH ..... 84  
 DECK LID LIGHT SOCKET ..... 83  
 DECK LID SEAL ..... 185  
 DECK LID STRIKER PLATE ..... 169  
 DECK LID SUPPORT ..... 186  
 DEFROSTER HOSE ..... 122  
 DEFROSTER KNOB ..... 123  
 DEFROSTER NOZZLE ..... 122  
 DIAL FACE GLASS (RADIO) ..... 125  
 DIAL FACE (RADIO) ..... 125  
 DIFFERENTIAL ..... 21 TO 23, 263  
 DIFFERENTIAL COVER PLATE ..... 178  
 DIMMER SWITCH ..... 80  
 DIP STICK ..... 36, 214, 215, 263  
 DIP STICK TUBE BOSS ..... 31  
 DISC BRAKE ..... 246, 247, 257, 258  
 DISTRIBUTOR BOOT ..... 70  
 DISTRIBUTOR CAP ..... 70  
 DISTRIBUTOR GASKET ..... 70  
 DISTRIBUTOR PARTS ..... 70, 71  
 DISTRIBUTOR PLUG ..... 107  
 DIVISION BAR (WINDSHIELD) ..... 71  
 DOME LAMP ..... 85  
 DOME LAMP LENS ..... 85  
 DOME LAMP SWITCH PLATE ..... 85  
 DOOR ARM RESTS ..... 169  
 DOOR ASSIST STRAPS ..... 162  
 DOOR BUMPERS ..... 158  
 DOOR CHECK ARM KITS ..... 162  
 DOOR CHECK ARM STRAPS ..... 162

DOOR DOVETAIL ..... 140  
 DOOR EDGE MIRRORS ..... 116  
 DOOR ESCUTCHEON PADS ..... 189-191  
 DOOR GLASS SEAL ..... 155, 156, 168  
 DOOR HANDLES (INSIDE) ..... 187 TO 189, 205  
 DOOR HANDLES (OUTSIDE) ..... 192, 193  
 DOOR HANDLE PADS ..... 193  
 DOOR HANDLE PINS ..... 189  
 DOOR HANDLE SETS ..... 187 TO 189  
 DOOR HINGE PINS ..... 131, 158  
 DOOR HINGES ..... 141  
 DOOR HINGE (GLOVE BOX) ..... 154  
 DOOR HINGE MIRROR ..... 116, 117  
 DOOR JAM SEALS ..... 163, 164  
 DOOR LATCHES ..... 141  
 DOOR LATCH PULL ..... 141, 162  
 DOOR LOCK ESCUTCHEON ..... 190  
 DOOR LOCK (OUTSIDE) ..... 162  
 DOOR MOULDINGS ..... 107  
 DOOR PANELS ..... 180  
 DOOR PANEL CLIPS ..... 129  
 DOOR PANEL SPRING ..... 190  
 DOOR PARTS ..... 140, 141  
 DOOR PATCH PANELS ..... 139, 140, 147, 148  
 DOOR PULLS ..... 162  
 DOOR REGULATOR ..... 161  
 DOOR SCUFF PLATES ..... 159  
 DOOR SEALS & RETAINER CHANNELS ..... 163, 164  
 DOOR SEAL (BACK EDGE) ..... 164  
 DOOR SEAL (HINGE) ..... 163  
 DOOR SEAL (LOWER) ..... 163  
 DOOR SEAL (UPPER) ..... 163  
 DOOR SPRING ..... 131, 141, 190  
 DOOR STRAP BRACKET ..... 162  
 DOOR STRIKER PAD ..... 140  
 DOOR STRIKER PLATES ..... 140  
 DOOR TRIM ..... 107  
 DOOR WINDOW CHANNEL KITS ..... 155 TO 158  
 DOOR WINDOW FRAME SEAL ..... 152  
 DOOR WINDOW RETAINER ..... 155 TO 157  
 DOOR WINDOW TRIM PANEL ..... 180  
 DOVETAILS ..... 140  
 DRAG LINK ..... 17, 252  
 DRAG LINK SEAL ..... 17  
 DRIVESHAFT PARTS ..... 23  
 DRIVESHAFT YOKE ..... 23  
 DROPPED AXLE ..... 245, 250  
 DUSTER ..... 109

## E

EDGE SEAL (DOOR) ..... 164  
 ELECTRICAL COMPONENTS (STREET ROD) ..... 205, 206, 262  
 ELECTRIC WIPER MOTORS ..... 110, 111  
 EMBLEM (FENDER) ..... 94  
 EMBLEM (GRILLE) ..... 45, 48, 49  
 EMBLEM (HOOD) ..... 48, 98, 99  
 EMBLEM (TRUNK) ..... 83  
 EMERGENCY BRAKE CABLES ..... 14, 15  
 EMERGENCY BRAKE HANDLES ..... 15  
 EMERGENCY CABLE BOOT ..... 14  
 EMERGENCY CABLE BRACKET ..... 13  
 EMERGENCY CABLE GROMMET ..... 12, 13, 57  
 EMERGENCY CABLE GUIDE ..... 13  
 ENGINE ADAPTERS ..... 42  
 ENGINE SPECIFICATION BOOKS ..... 220 TO 226  
 ENGINE CROSSMEMBERS (STREET ROD) ..... 212, 246, 248  
 ENGINE MOUNTS (STREET ROD) ..... 212, 261  
 ENGINE OIL COOLER ..... 260  
 ENGINE PARTS ..... 31 TO 36  
 ENGINE SPLASH PANS ..... 36  
 ENGINE WIRING ..... 67  
 ESCUTCHEON (DOOR HANDLE) ..... 190, 191  
 ESCUTCHEON (DOOR LOCK) ..... 190  
 ESCUTCHEON (VENT WINDOW) ..... 190  
 ESCUTCHEON (WINDOW CRANK) ..... 191  
 EXHAUST DEFLECTORS ..... 122  
 EXHAUST MANIFOLDS ..... 56  
 EXHAUST PIPES ..... 27, 28  
 EXHAUST SYSTEM ..... 27, 28  
 EXHAUST SYSTEM (STREET ROD) ..... 263

## F

FAN ASSEMBLY ..... 51, 62, 260  
 FAN BELTS ..... 51  
 FAN SHROUD (STREET ROD) ..... 43  
 FEMALE DOVETAILS ..... 140  
 FENDER APRON ..... 93, 94, 195, 199  
 FENDER APRON BOLTS ..... 93, 129  
 FENDER APRON BUMPER ..... 94  
 FENDER BOLT KIT ..... 92, 134  
 FENDER BOOTS (REAR) ..... 94  
 FENDER BRACES ..... 92, 94  
 FENDER BRACE PANEL ..... 93, 94  
 FENDER CLAMP ..... 93  
 FENDER-TO-COWL SEAL ..... 93  
 FENDER EMBLEM ..... 94  
 FENDER GROMMET ..... 120  
 FENDER GUARD ..... 94  
 FENDER MOULDINGS ..... 92



FENDER PANELS (INNER) ..... 94  
 FENDERS ..... 94, 195 to 199  
 FENDER PATCH PANELS ..... 95  
 FENDER SKIRTS (FIBERGLASS) ..... 200  
 FENDER SKIRT SEALS ..... 122  
 FENDER TRIM ..... 92  
 FENDER WELTING ..... 93  
 FENDER WELT (STAINLESS) ..... 93  
 FIBERGLASS BODIES ..... 194  
 FIBERGLASS DASH INSULATORS ..... 181  
 FIBERGLASS GRILLES ..... 201  
 FIBERGLASS FENDERS ..... 195 to 199  
 FIBERGLASS PARTS ..... 145, 194 to 204  
 FINGER PULL (WINDSHIELD) ..... 144  
 FIREWALL COVER CLIP ..... 181  
 FIREWALL GROMMET ..... 57  
 FIREWALL INSULATION ..... 181  
 FIREWALL SEAL ..... 138, 210  
 FIREWALL (STEEL) ..... 210  
 FLATHEAD SPEED EQUIPMENT ..... 42  
 FLOORBOARD SEALS ..... 137, 138  
 FLOORBOARDS ..... 172, 210  
 FLOOR COVER (BATTERY) ..... 172, 178  
 FLOOR COVER (TRANSMISSION) ..... 178  
 FLOOR MATS ..... 179  
 FLOOR MAT CLIP ..... 129, 179  
 FLOOR PAN ..... 147, 227-229  
 FLOOR PLUG ..... 138  
 FLOOR SEAL (STEERING TUBE) ..... 137  
 FLOOR SEAL (TRANSMISSION) ..... 137  
 FLOOR SHIFTER (STREET ROD) ..... 283  
 FLYWHEEL RING GEAR ..... 35  
 FOG LAMPS ..... 91  
 FOOT REST ..... 57  
 FORD PORCELAIN EMBLEM ..... 48  
 FORD PARTS TAGS ..... 124  
 FORD SCRIPT (HOOD) ..... 98, 99  
 FORD SIGN ..... 124  
 FRAME - STREET ROD ..... 233, 242, 243  
 FRAME BOXING PLATE ..... 264  
 FRAME HORN ..... 26  
 FRAME HORN COVERS ..... 95, 200  
 FRAME PAD ..... 25  
 FRAME PARTS ..... 25, 26  
 FRAME WEBBING ..... 25  
 FRAME (WINDSHIELD) ..... 142  
 FRAME WIRE CLIP ..... 69  
 FRONT AXLE ..... 16, 17  
 FRONT SUSPENSION (STREET ROD) ..... 245-251  
 FRONT FENDERS (FIBERGLASS) ..... 195 to 199  
 FUEL GAUGE ..... 54  
 FUEL GAUGE LIQUID ..... 54, 64  
 FUEL LINE ..... 55  
 FUEL PUMP ..... 55  
 FUEL SYSTEMS ..... 53 to 56  
 FUEL TANK ..... 53, 216  
 FUEL TANK-TO-SENDING UNIT ADAPTERS ..... 211

GEAR SHIFT GROMMET ..... 39, 40  
 GEAR SHIFT INDICATOR ..... 207  
 GEAR SHIFT KNOBS ..... 39, 59  
 GEAR SHIFT REPAIR KIT ..... 40  
 GENERATOR BELTS ..... 51  
 GENERATOR PARTS ..... 63, 206  
 GLASS BUMPER ..... 158  
 GLASS PATTERNS ..... 142  
 GLASS SETTING TAPE ..... 143  
 GLOVE BOX ..... 154  
 GLOVE BOX DOOR ..... 108, 202  
 GLOVE BOX DOOR BUMPER ..... 154  
 GLOVE BOX DOOR HINGE ..... 154  
 GLOVE BOX DOOR REPAIR KIT ..... 154  
 GLOVE BOX DOOR SPRING ..... 154  
 GLOVE BOX DOOR STOP ..... 154  
 GLOVE BOX LOCK ..... 154  
 GLUE, RUNNING BOARD COVER ..... 95, 218  
 GLUE, WEATHERSTRIP ..... 185, 218  
 GRAVEL DEFLECTOR ..... 119, 120, 204  
 GREASE FITTINGS ..... 15, 51, 133  
 GREYHOUND RADIATOR ORNAMENTS ..... 49  
 GRILLE BARS ..... 44, 45, 47  
 GRILLE BUMPERS ..... 120  
 GRILLE CENTER ..... 44, 45, 50  
 GRILLE CLIPS ..... 44, 80, 129  
 GRILLE COMPONENTS ..... 44 to 50, 209  
 GRILLE, DELUXE ..... 46  
 GRILLE EMBLEM ..... 45, 48, 49, 76  
 GRILLE GUARDS ..... 120  
 GRILLE GUARD STIFFENER ..... 120  
 GRILLE HARDWARE KIT ..... 130  
 GRILLE INSERTS ..... 46, 47, 209  
 GRILLE MOULDING CLIPS ..... 50, 106, 129  
 GRILLE MOULDINGS ..... 50, 106  
 GRILLE ORNAMENTS ..... 45, 48  
 GRILLE PAD ..... 120  
 GRILLE PAN ..... 45, 47, 52  
 GRILLE PAN BUMPER ..... 120  
 GRILLE PARTS ..... 44 TO 50, 209  
 GRILLE SCREEN ..... 45  
 GRILLE SCRIPTS ..... 213  
 GRILLE SHELL ..... 46, 201, 209  
 GRILLE SHELL GROMMET ..... 88  
 GRILLE SHELL ORNAMENTS ..... 48, 49  
 GRILLE, STANDARD ..... 48  
 GRILLE SUPPORT ..... 44, 47, 52  
 GRILLE TRIM ..... 44 to 50, 106  
 GRILLE-TO-FENDER APRON ..... 50  
 GRILLE VENT PANELS ..... 94  
 GROMMETS ..... 57  
 GUARD, BUMPER ..... 119  
 GUARD, FENDER ..... 94  
 GUSSET PLATE ..... 178

HEATER HOSE CONNECTOR ..... 91, 122  
 HEATER KNOB ..... 123  
 HEATER PARTS ..... 91, 122, 123  
 HIGH BEAM JEWEL ..... 84  
 HINGE, DOOR SEAL ..... 163  
 HINGE PAD, HOOD ..... 103  
 HINGE PINS ..... 131, 158  
 HINGES (TRUNK LID) ..... 186  
 HOG RINGS ..... 165  
 HOOD ARM SPRING ..... 103  
 HOOD BOLTS ..... 99  
 HOOD BRACKETS ..... 47, 102  
 HOOD BUMPER KITS ..... 105  
 HOOD CENTER ..... 102, 103  
 HOOD CLIPS ..... 103  
 HOOD EMBLEMS ..... 49, 98, 99  
 HOOD HANDLES ..... 49, 102, 103  
 HOOD HANDLE & LATCH MOUNTING KIT ..... 135  
 HOOD HANDLE PIN ..... 49  
 HOOD HANDLE SPRING BRACKET ..... 102  
 HOOD HINGE BRACKETS ..... 47, 209, 263  
 HOOD HINGE ..... 103, 209  
 HOOD HINGE HARDWARE KIT ..... 105  
 HOOD HINGE PAD ..... 103  
 HOOD LACE ..... 104  
 HOOD LATCHES ..... 103, 209, 263  
 HOOD LATCH CLIP ..... 103  
 HOOD LATCH SPRINGS ..... 103  
 HOOD MOULDING CLIPS ..... 129  
 HOOD ORNAMENTS ..... 48, 49, 98, 99, 103  
 HOOD ORNAMENT BASE PADS ..... 50, 103  
 HOOD ORNAMENT MOUNTING KIT ..... 49  
 HOOD PARTS ..... 98 to 106, 209  
 HOOD PULL GROMMET ..... 57  
 HOOD RELEASE HANDLE ..... 49  
 HOOD RELEASE KIT ..... 264  
 HOOD SAFETY CATCH ..... 106  
 HOODS ..... 99 to 101  
 HOOD SIDE MOULDINGS ..... 102, 103, 106  
 HOOD STOP BRACKETS ..... 106  
 HOOD SUPPORT ..... 102, 209  
 HOOD SUPPORT ARM ..... 103  
 HOOD TRIM ..... 50, 102, 103, 106  
 HORN BOLT ..... 86  
 HORN BRACKETS ..... 86  
 HORN BUTTON ..... 20  
 HORN BUTTON CUSHION ..... 20  
 HORN BUTTON SPRING ..... 19  
 HORN BUTTON WIRE ..... 20, 68  
 HORN COVER ..... 85, 86  
 HORN GRILLE ..... 86  
 HORN GRILLE PAD ..... 86  
 HORN GROMMET ..... 86  
 HORN/LIGHT SWITCH ROD ..... 20  
 HORN MOTOR WIRING ..... 67, 86  
 HORN RODS ..... 20  
 HORN SCREEN ..... 86  
 HORN TAG ..... 86  
 HORN WIRE ..... 20, 68, 86  
 HORNS ..... 20, 85, 86  
 HOSE CLAMPS ..... 51, 53  
 HOSE, RADIATOR ..... 51  
 HUBCAPS ..... 6, 7  
 HUB PARTS ..... 8 to 10  
 HYDEM WELT ..... 160  
 HYDRAULIC BRAKE ADAPTER KIT ..... 15

G

GARNISH MOULDING ..... 143, 145, 203  
 GARNISH MOULDING INSERTS ..... 145  
 GAS APRON CHANNEL SEAL KIT ..... 95  
 GAS CAPS ..... 53, 211  
 GAS GAUGE COVER ..... 53  
 GAS LID BUMPER ..... 53, 103  
 GAS NECK CLAMP ..... 53  
 GAS NECK GROMMET ..... 54  
 GAS NECK HOSE ..... 53  
 GAS PEDAL ..... 57  
 GAS PEDAL ROD ..... 57  
 GAS SENDER GASKET ..... 54  
 GAS SENDER FLOAT ..... 54  
 GAS TANK ..... 53, 216  
 GAS TANK BOLT ..... 53  
 GAS TANK COVER ..... 96  
 GAS TANK COVER (FIBERGLASS) ..... 200  
 GAS TANK COVER SCREW ..... 132  
 GAS TANK PAD ..... 55  
 GAS TANK PARTS ..... 53 to 55  
 GAS TANK SEALER ..... 53, 218  
 GAS TANK SENDING UNIT ..... 54, 211  
 GASKET, COWL VENT ..... 138  
 GASKET, DECK LID ..... 94  
 GASKET, DISTRIBUTOR ..... 70  
 GASKET, HEADLIGHT ..... 75, 76  
 GASKET, HOOD ORNAMENT ..... 50, 103  
 GASKET, INSTRUMENT PANEL ..... 54  
 GASKET, LICENSE BRACKET ..... 80  
 GASKET, LICENSE LIGHT ..... 80  
 GASKET, PARKING LIGHT ..... 77  
 GASKET, STEERING BOX ..... 18  
 GASKET, TAIL LIGHT ..... 81  
 GAUGE FACES ..... 54, 55, 109  
 GAUGE, TEMPERATURE ..... 84  
 GAUGES (STREET ROD) ..... 262  
 GEAR OIL ..... 218  
 GEAR SHIFT BOOT ..... 40, 137

H

HALOGEN REFLECTOR KIT ..... 75  
 HANDLE, COWL VENT ..... 138  
 HANDLES (DECK LID) ..... 83, 84  
 HANDLES, DOOR ..... 187 to 193  
 HANDLE, DOOR OUTSIDE ..... 192, 193  
 HANDLE, PULL ..... 162  
 HANDLE, WINDSHIELD ..... 183  
 HEAD GASKETS ..... 30  
 HEADER BRACKET ..... 151  
 HEADER BUMPER ..... 153  
 HEADER SEAL ..... 145, 153  
 HEADER STRIP, METAL ..... 144  
 HEADLAMP ..... 74  
 HEADLAMP ADAPTER ..... 74  
 HEADLAMP BARS ..... 76  
 HEADLAMP BOLTS ..... 76, 132  
 HEADLAMP BUCKETS ..... 73  
 HEADLAMP CLIP ..... 76  
 HEADLAMP CONDUIT ..... 88  
 HEADLAMP CONDUIT REPAIR ..... 88  
 HEADLAMP GROMMET ..... 88  
 HEADLAMP LENS ..... 76  
 HEADLAMP PADS ..... 76  
 HEADLAMP PARTS ..... 73 to 76  
 HEADLAMP PLUG ..... 88  
 HEADLAMP, QUARTZ BULB ..... 74  
 HEADLAMP REFLECTOR ..... 75  
 HEADLAMP PIMS ..... 75  
 HEADLAMP RIM REPAIR KIT ..... 72, 132  
 HEADLAMP RIM SCREWS ..... 75, 132  
 HEADLAMP, SEALED BEAM ..... 73, 74  
 HEADLAMP SHELL GROMMET ..... 88  
 HEADLAMP SHELL REPAIR ..... 72, 132  
 HEADLAMP STAND ..... 76  
 HEADLAMP WIRE ..... 66, 67  
 HEADLAMP WIRE CROSSOVER CHANNEL ..... 66  
 HEADLINER ..... 180  
 HEATER ..... 122, 123, 205  
 HEATER HOSE ..... 122  
 HEATER HOSE BRACKET ..... 91  
 HEATER HOSE CLAMPS ..... 122

I

IGNITION CYLINDER ..... 20  
 IGNITION KEYS ..... 20, 162  
 IGNITION LOCK SHIM ..... 20  
 IGNITION POINTS ..... 70  
 IGNITION RESISTOR ..... 71  
 IGNITION SWITCH ..... 20  
 IGNITION SWITCH PLATES ..... 66  
 INDEPENDENT FRONT SUSPENSION ..... 248-249  
 INSERT, GARNISH MOULDING ..... 145  
 INSIDE REARVIEW MIRRORS ..... 114, 115  
 INSTRUMENT GAUGE GLASS ..... 64  
 INSTRUMENT PANEL ..... 60, 108, 206  
 INSTRUMENT PANEL DIMMER SWITCH ..... 84  
 INSTRUMENT PANEL FACE SETS ..... 109  
 INSULATION, BODY ..... 181  
 INSULATION, FIREWALL ..... 181  
 INTAKE MANIFOLD GASKET ..... 35  
 INTAKE MANIFOLD WASHER ..... 133  
 INTERIOR TRIM SCREW KITS ..... 130

K

KICK PANELS ..... 180  
 KICK PANEL RETAINERS ..... 180  
 KICK PANEL TRIM ..... 180  
 KICKDOWN KITS ..... 214, 215  
 KNOB PINS ..... 16, 250  
 KNOB, ANTENNA ..... 127

# INDEX

KNOB, ASH TRAY ..... 61  
 KNOB, CIGAR LIGHTER ..... 90  
 KNOB, CONVERTIBLE TOP ..... 153  
 KNOB, COWL VENT ..... 59  
 KNOBS (DASH) ..... 58, 59  
 KNOB, DEFROSTER ..... 123  
 KNOB, GEAR SHIFT ..... 39, 59  
 KNOB, HEATER ..... 123  
 KNOB, RADIO ..... 125  
 KNOB, WINDOW CRANK ..... 183, 190

## L

LADDER BAR KITS ..... 212  
 LATCH, TRUNK ..... 84  
 LENS, BLUE DOT ..... 81  
 LENS, COWL LIGHT ..... 78  
 LENS, DECK BASE ..... 81  
 LENS, DOME LIGHT ..... 85  
 LENS, HEADLIGHT ..... 76  
 LENS, LICENSE PLATE LIGHT ..... 80, 81  
 LENS, PARKING LIGHT ..... 77  
 LENS, TAIL LIGHT ..... 81  
 LICENSE HOLDER (FRONT) ..... 25, 82  
 LICENSE LAMP ..... 83  
 LICENSE LENS CLIP ..... 80  
 LICENSE LIGHT ..... 83, 263  
 LICENSE PLATE BACK ..... 213  
 LICENSE PLATE BOLT ..... 82  
 LICENSE PLATE BRACKET ..... 82  
 LICENSE PLATE FRAMES ..... 83, 263  
 LICENSE PLATE LIGHT LENS ..... 80, 81  
 LICENSE PLATE PAD, GASKET ..... 81, 84  
 LIGHT BULB ..... 74, 81, 211  
 LIGHT, COWL ..... 77, 78  
 LIGHT, HEAD ..... 74 to 76  
 LIGHT, PARKING ..... 77  
 LIGHT SWITCH BODY ..... 66  
 LIGHT SWITCH/HORN ROD ..... 20  
 LIGHT, TAIL ..... 78, 79, 208  
 LIGHTERS ..... 90, 91, 108  
 LOCK CYLINDER, DOOR ..... 162  
 LOCK, GLOVE BOX ..... 154  
 LOCKING GAS CAP ..... 53  
 LOOM, WIRE CONDUIT ..... 67, 69, 88, 213  
 LOWER DOOR SEAL ..... 163  
 LUG WRENCH ..... 109  
 LUGGAGE RACKS ..... 124  
 LUGGAGE RACK EMBLEM ..... 124

## M

MAIN BEARINGS ..... 34  
 MALE DOVETAILS ..... 140  
 MANIFOLD (EXHAUST) ..... 56  
 MAP CASE ..... 109  
 MASTER CYLINDER ..... 13, 269  
 MASTER CYLINDER COVER PLATE ..... 138  
 MASTER CYLINDER MOUNT BRACKET ..... 211  
 MASTER CYLINDER REPAIR KIT ..... 11  
 METAL TOP MOULDING ..... 160  
 MIRRORS ..... 114 to 117, 205  
 MIRROR, BRACKET INTERIOR ..... 115  
 MIRROR, DOOR HINGE ..... 116, 117  
 MIRROR, EXTERIOR ..... 116, 117, 205  
 MIRROR, INTERIOR ..... 114, 115, 205  
 MIRROR HEAD, DOOR ..... 116, 117  
 MIRROR HEAD, INTERIOR ..... 116  
 MOTOR MOUNTS (FRONT) ..... 31, 212, 261  
 MOTOR MOUNTS (REAR) ..... 32  
 MOULDINGS (BODY) ..... 107  
 MOULDING CLIP KITS ..... 129  
 MOULDING (TOP) ..... 160  
 MUFFLER ..... 27  
 MUFFLER SUPPORT ..... 28

## O

OIL CHEX GAUGE ..... 84  
 OIL COOLER ..... 260  
 OIL FILLER CAPS ..... 36  
 OIL GAUGE ..... 54, 64  
 OIL PAN GASKET SET ..... 36  
 OIL PUMP ..... 36  
 OPERA SEAT BUMPER ..... 165  
 OUTSIDE REARVIEW MIRRORS ..... 116, 117, 205  
 OVERHAUL GASKET SETS ..... 30

## P

PACKAGE TRAY (WOOD) ..... 171  
 PAD, COWL LIGHT ..... 78  
 PAD, HORN GRILLE ..... 86  
 PAD, RUMBLE STEP ..... 149  
 PAINT, ENGINE ..... 31, 218  
 PAINT, STEERING WHEEL ..... 19  
 PANEL, DASH ..... 60-62, 106, 205  
 PANHARD BAR ..... 249, 256  
 PARALLEL LINK ..... 249  
 PARKING LAMPS ..... 77  
 PARKING LAMP BOOT ..... 77

PARKING LAMP LENS ..... 77  
 PARKING LAMP LENS CLIP ..... 77  
 PARKING LAMP PAD ..... 77  
 PARKING LAMP WIRE ..... 77  
 PATCH PANELS ..... 95, 139, 140, 147, 227-229  
 PATENT DATA PLATES ..... 124  
 PEDAL BUMPERS ..... 14, 137  
 PEDAL COVER PLATES ..... 178  
 PEDAL PADS ..... 14  
 PEDAL SEALS ..... 137  
 PEEP MIRRORS ..... 116, 117  
 PICKUP BED PARTS ..... 172 to 177  
 PICKUP BEDS ..... 173  
 PICKUP BED SIDE PANELS ..... 175  
 PICKUP BED STRIPS ..... 176  
 PIN, DOOR HANDLE ..... 189  
 PISTON RINGS ..... 32, 33  
 PISTONS ..... 32  
 PITMAN ARM ..... 18, 252  
 PLUG, ANTENNA HOLE ..... 127  
 PLUG WIRES ..... 71  
 POLY-RIDE ..... 251  
 PORCELAIN GRILLE EMBLEM ..... 48  
 POWER ACCESSORY BLOCK ..... 207  
 POWER BRAKE ..... 258  
 POWER WINDOW KITS ..... 213

## Q

QUAIL RADIATOR ORNAMENT ..... 49  
 QUARTER GLASS RUBBER ..... 184  
 QUARTER MOULDINGS ..... 107  
 QUARTER PANEL BRACES ..... 139  
 QUARTER PATCH PANELS ..... 139  
 QUARTER TOP PADS ..... 153  
 QUARTZ BULB ..... 74

## R

RACK & PINION ..... 252  
 RADIATOR BOLT KIT ..... 43, 52  
 RADIATOR CAPS ..... 43, 260  
 RADIATOR CAP REPAIR KIT ..... 43, 49  
 RADIATOR FAN SHROUD ..... 43  
 RADIATOR/FENDER BRACKET ..... 43, 94  
 RADIATOR GRILLE PAN ..... 50, 52, 98  
 RADIATOR GRILLE SHIELD ..... 52  
 RADIATOR HOSE ..... 51  
 RADIATOR HOSE CLAMP ..... 51  
 RADIATOR HOSE, LOWER ..... 51  
 RADIATOR HOSE, UPPER ..... 51  
 RADIATOR OVERFLOW TANKS ..... 260  
 RADIATORS ..... 43, 260  
 RADIATOR SHELL LACING ..... 104  
 RADIATOR SHELL MOUNTING ..... 135  
 RADIATOR SHROUD SEAL ..... 52  
 RADIATOR SPLASH APRONS ..... 98, 200  
 RADIATOR SUPPORT RODS ..... 44  
 RADIATOR SUPPORT ROD BRACKET ..... 44  
 RADIO ANTENNAES ..... 126, 127  
 RADIO CHANGER BUTTON ..... 125  
 RADIO COVER ..... 125, 209  
 RADIO DIAL ..... 125  
 RADIO DIAL BEZEL ..... 125  
 RADIO DIAL FACE ..... 125  
 RADIO DIAL FACE GLASS ..... 125  
 RADIO INSTALLATION BOOK ..... 126  
 RADIO KNOB ..... 108, 125  
 RADIO MOUNTING HOOK ..... 126  
 RADIO PANEL ..... 61, 108, 125  
 RADIO PARTS ..... 125 to 127  
 RADIO NUT ..... 126  
 RADIO SPEAKER BOOT ..... 126  
 RADIO SPEAKER CLOTH ..... 126  
 RADIO SPEAKER GRILLE ..... 61, 127  
 RADIO STATION SELECTOR ..... 125  
 RADIUS ROD ..... 244  
 RADIUS ROD BUSHING ..... 17  
 REAR AXLE ..... 22  
 REAR AXLE ASSEMBLIES (STREET ROD) ..... 253  
 REAR END COVER ..... 178  
 REAR FENDERS (FIBERGLASS) ..... 195 to 199  
 REAR QUARTER WINDOW RUBBER ..... 184  
 REAR SUSPENSION (STREET ROD) ..... 253-256  
 REAR WINDOW BUMPER ..... 151, 154  
 REAR WINDOW DRAIN ..... 148  
 REAR WINDOW SEAL ..... 184  
 REAR WINDOW STRAP ..... 151  
 REFLECTOR, HEADLAMP ..... 75  
 REGULATOR HANDLE ..... 189  
 REGULATORS (WINDOW) ..... 181  
 REGULATOR, WINDSHIELD ..... 182  
 RESISTOR ..... 71  
 RESTORATION SUPPLIES ..... 218  
 RIM LINERS ..... 10

RING & PINION GEARS ..... 21  
 RIVETS ..... 129  
 ROADSTER TOP IRONS ..... 151, 204  
 ROCKER PANELS ..... 139  
 ROD BEARINGS ..... 33  
 ROOF RIB WOOD KITS ..... 171  
 ROTOR (DISTRIBUTOR) ..... 71  
 RUBBER (WINDSHIELD) ..... 182  
 RUMBLE BUMPERS ..... 149, 185  
 RUMBLE HANDLES ..... 83, 150  
 RUMBLE HANDLE PAD ..... 84  
 RUMBLE HINGE KITS ..... 149  
 RUMBLE LATCH ..... 84  
 RUMBLE LID SEAL ..... 185  
 RUMBLE SEAT PARTS ..... 149, 150  
 RUMBLE SEAT RAIN GUTTERS ..... 148  
 RUMBLE STEP ..... 149  
 RUMBLE STEP BRACKET ..... 149  
 RUMBLE TRIP LEVER ..... 150  
 RUNNING BOARD ..... 95 to 97  
 RUNNING BOARD BOLT ..... 95, 134  
 RUNNING BOARD BRACES ..... 97  
 RUNNING BOARD COVERS ..... 97  
 RUNNING BOARD COVER GLUE ..... 95, 218  
 RUNNING BOARD PAD ..... 25  
 RUNNING BOARD MOULDINGS ..... 97  
 RUNNING BOARD TRIM CLIP KIT ..... 97  
 RUNNING BOARDS (FIBERGLASS) ..... 200  
 RUNNING BOARD STEP PLATES ..... 95

## S

SAFETY SWITCH (NEUTRAL) ..... 207  
 SAGINAW STEERING MOUNT ..... 208  
 SCREEN, COWL VENT ..... 138  
 SCREEN, HORN ..... 86  
 SCREW, COWL LIGHT ..... 78, 132  
 SCREW, DASH ..... 136  
 SCREW, DOOR HANDLE ..... 130  
 SCREW, DOOR HINGE ..... 131  
 SCREW, DOOR SCUFF ..... 132  
 SCREW, DOVETAIL ..... 131  
 SCREW, FLOORBOARD ..... 133  
 SCREW, FRONT FENDER ..... 134  
 SCREW, HEADLAMP RIM ..... 75, 132  
 SCREW, HOODLATCH ..... 135  
 SCREW KIT, INTERIOR ..... 130  
 SCREW, RADIATOR SHELL ..... 135  
 SCREW, REAR WINDOW ..... 134  
 SCREW, TAILLIGHT ..... 131  
 SCREW, WINDSHIELD FRAME ..... 133  
 SCUFF PLATES (DOOR) ..... 159  
 SEALED BEAM HEADLAMP ..... 73, 74  
 SEALED BEAM ADJUSTMENT KIT ..... 73  
 SEAT ADJUST HANDLE ..... 161  
 SEAT, BENCH (STREET ROD) ..... 164  
 SEATS (STREET ROD) ..... 164  
 SEAT FRAME SUPPORTS ..... 186  
 SEAT RELEASE PARTS ..... 161  
 SEAT SPRINGS ..... 165 to 168  
 SEAT SPRING LOCATING PIN ..... 186  
 SEAT WOOD ..... 170  
 SENDING UNIT (GAS) ..... 54, 211  
 SENDING UNIT, TEMPERATURE ..... 64  
 SHACKLE KITS ..... 28, 251  
 SHEETMETAL, BODY CHANNEL ..... 147  
 SHEETMETAL, DECK GUTTER ..... 148  
 SHEETMETAL, FLOOR ..... 147, 227-229  
 SHEETMETAL, FLOOR EXTENSION ..... 147, 227  
 SHEETMETAL, GRILLE ..... 44, 45, 47, 50  
 SHEETMETAL, PACKAGE TRAY ..... 147  
 SHEETMETAL, PATCH PANEL ..... 139, 140, 147  
 SHEETMETAL, RUMBLE RISER ..... 147  
 SHEETMETAL, SEAT ADJUSTER ..... 147  
 SHEETMETAL, SEAT FRAME ..... 147  
 SHEETMETAL, SEAT PANEL ..... 148  
 SHEETMETAL, SEAT RISER ..... 147  
 SHEETMETAL, UNDER DECK LID ..... 146  
 SHEETMETAL, UNDER SEAT ..... 147, 227-229  
 SHEETMETAL, WINDOW DRAIN ..... 148  
 SHIFT BOOT ..... 40, 137  
 SHIFT KNOB ..... 39, 59  
 SHIFT LEVER GROMMET ..... 39, 40  
 SHIFT LINKAGE REPAIR KIT ..... 40  
 SHIFTER (STREET ROD) ..... 215, 263  
 SHIMS (FRAME) ..... 25  
 SHOCK KIT ..... 121, 209, 249  
 SHOCK LINK BALL ..... 121  
 SHOCK MOUNT ..... 121, 251  
 SHOCK ABSORBER PARTS ..... 121  
 SIDE CURTIN ROD SOCKETS ..... 134  
 SIDEMOUNT MIRROR ..... 114  
 SILL PLATE, DOOR ..... 159  
 SIGRTS ..... 200  
 SOCKET, HIGH BEAM JEWEL ..... 84  
 SPARE TIRE COVER TRIM ..... 10, 122  
 SPARE TIRE COVER SEAL ..... 10  
 SPARE TIRE GROMMET ..... 10  
 SPARE TIRE HOLD-DOWN BRACKET ..... 122  
 SPARE TIRE PAD ..... 10

SPARK PLUGS ..... 72  
 SPARK PLUG LOOM ..... 72, 213  
 SPARK PLUG WIRES ..... 71  
 SPARK PLUG WIRE BOOT ..... 70  
 SPEAKER CLOTH ..... 126  
 SPEAKER GRILLE ..... 61, 127  
 SPEED EQUIPMENT (FLATHEAD) ..... 42  
 SPEEDOMETER CABLES ..... 110  
 SPEEDOMETER CABLE BRACKET ..... 110  
 SPEEDOMETER CABLE GROMMET ..... 57  
 SPEEDOMETER FACES ..... 109  
 SPEEDOMETER FACE GLASS ..... 64  
 SPINDLE ..... 246, 250  
 SPINDLE BOLT KITS ..... 16, 250  
 SPOTLIGHTS ..... 123  
 SPREADER BARS ..... 26, 263  
 SPRING, BRAKE/CLUTCH ..... 11, 14, 40, 41  
 SPRING, CLAMP ..... 28, 251  
 SPRING COVERS ..... 122  
 SPRING, COWL VENT ..... 138  
 SPRING, DOOR ..... 141  
 SPRING, DOOR PANEL ..... 190  
 SPRING (FRONT) ..... 28, 213, 251  
 SPRING, GLOVE BOX DOOR ..... 154  
 SPRING, HOOD ARM & LATCH ..... 103  
 SPRING, HORN BUTTON ..... 19  
 SPRING, LINER ..... 254  
 SPRING, MOUNTING KIT ..... 212, 254  
 SPRING PARTS ..... 28, 29, 251  
 SPRING PERCH ..... 16, 212, 251  
 SPRING, PERCH NUT ..... 18  
 SPRINGS (SEAT) ..... 165 to 168  
 SPRING, SHACKLE ..... 28, 254  
 SPRING, "U" BOLT ..... 29, 254  
 STABILIZER BAR ..... 29  
 STABILIZER BUSHING ..... 29  
 STABILIZER SWIVEL ..... 16  
 STARTER BUTTON ..... 59  
 STARTER PARTS ..... 65  
 STEERING ARM ..... 250  
 STEERING BOX PARTS ..... 17 to 19  
 STEERING COMPONENTS (STREET ROD) ..... 208, 250, 252  
 STEERING COLUMN ..... 214, 252  
 STEERING COLUMN DROPS ..... 215, 252  
 STEERING FLOOR PLATES ..... 137, 178, 215  
 STEERING GEAR ..... 252  
 STEERING SECTOR ..... 18  
 STEERING SHAFT BUSHING ..... 17  
 STEERING TUBE FLOOR PLATE ..... 137  
 STEERING TUBE SEALS ..... 137, 138  
 STEERING U-JOINTS ..... 208  
 STEERING WHEELS ..... 19, 232  
 STEERING WHEEL PAINT ..... 19, 218  
 STEP, RUMBLE ..... 149  
 STONE DEFLECTOR (BUMPER) ..... 120, 204  
 STONE GUARD ..... 94  
 STOP LIGHT SWITCH ..... 80  
 STRIKER PLATE, DECK ..... 150, 189  
 STRIKER PLATE, DOOR ..... 140  
 STRIKER PLATE PAD ..... 140  
 SUICIDE DOOR SAFETY LOCK ..... 141  
 SUN VISORS ..... 160  
 SUN VISOR ROD ..... 151, 160  
 SUN VISOR BRACKET ..... 151  
 SUSPENSION COMPONENTS (STREET ROD) ..... 245-256  
 SWITCH, DASH LIGHT ..... 84  
 SWITCH LEVER, IGNITION ..... 20  
 SWITCH, NEUTRAL SAFETY ..... 207  
 SWITCH, UNIVERSAL ..... 108  
 SWITCH PLATE, IGNITION ..... 66

**T**

T-SHIRTS ..... 230, 231, INSIDE BACK COVER  
 TAG, FORD SCRIPT ..... 124  
 TAIL GATES ..... 174  
 TAIL GATE BUMPER ..... 164  
 TAIL LAMP BRACE ..... 80  
 TAIL LAMP BRACKETS ..... 79, 80  
 TAIL LAMP CONDUIT REPAIR ..... 88  
 TAIL LAMP HALOGEN CONVERSION ..... 208  
 TAIL LAMP LENS ..... 81  
 TAIL LAMP PAD ..... 82  
 TAIL LAMP PARTS ..... 78 to 82  
 TAIL LAMP REFLECTOR ..... 80  
 TAIL LAMP RING ..... 80  
 TAIL LAMPS ..... 78, 79, 213  
 TAIL LAMP TRIM ..... 79  
 TAIL LAMP SCREWS ..... 131  
 TAIL LAMP SOCKET ..... 69  
 TAIL LAMP WIRING ..... 69  
 TAIL PIPE ..... 27  
 TANDEM WIPER ..... 112  
 TAPE, GLASS SETTING ..... 143  
 TEMPERATURE GAUGE ..... 64  
 TEMPERATURE GAUGE HOSE FITTING ..... 122  
 TEMPERATURE SENDER ..... 64  
 THERMOSTAT ..... 51  
 THERMOSTAT HOUSING ..... 260  
 THROTTLE ASSEMBLY ..... 56, 57, 205, 214

THROTTLE CABLE (STREET ROD) ..... 214  
 THROTTLE CABLE KITS ..... 62  
 THROTTLE RODS ..... 56  
 TIE RODS ..... 16, 252  
 TIE ROD CLAMP ..... 127  
 TIE ROD ENDS ..... 17, 252  
 TIE ROD JAM NUT ..... 263  
 TIE ROD SEAL ..... 17  
 TIRE COVERS ..... 10  
 TIRES ..... 10  
 TIRE COVER TRIM ..... 10  
 TIRE TUBES ..... 10  
 TOOL BAG (OAK) ..... 109  
 TOP BOWS (OAK) ..... 171  
 TOP BOW PADS ..... 152  
 TOP BOW SEAL ..... 145, 153  
 TOP DECK MATERIAL ..... 160  
 TOP DECK RETAINER ..... 160  
 TOP HOLD-DOWN ..... 151, 153, 154  
 TOP IRONS ..... 151, 204  
 TOP IRON RIVET COVERS ..... 151  
 TOP KNOBS (CONVERTIBLE) ..... 153  
 TOP MATERIAL ..... 160  
 TOP MOULDINGS ..... 160  
 TOP REST BRACKET ..... 153  
 TOP REST SCREW ..... 134  
 TRAILING ARMS ..... 255  
 TRANSMISSION COVERS ..... 178  
 TRANSMISSION COVER FASTENER KIT ..... 133  
 TRANSMISSION MOUNT ..... 32  
 TRANSMISSION-TO-FLOOR SEAL ..... 137  
 TRANSMISSION PARTS ..... 37 to 41  
 TRANSMISSION SHIFTER ..... 215, 263  
 TRIM, BODY ..... 102, 107  
 TRIM CEMENT ..... 158, 218  
 TRIM CLIP KITS ..... 129, 130  
 TRIM, DASH ..... 60  
 TRIM, HOOD ..... 102, 103, 106, 107  
 TRIM, KICK PANEL ..... 160  
 TRIM RING (SPARE TIRE) ..... 10  
 TRIM, RUNNING BOARD ..... 97  
 TRIM SCREW KITS ..... 129, 130  
 TRUNK ARM SUPPORT ..... 186  
 TRUNK EMBLEM ..... 83  
 TRUNK GUSSETS ..... 148  
 TRUNK HANDLES ..... 83, 84  
 TRUNK HANDLE NUT ..... 132  
 TRUNK HANDLE PAD ..... 84  
 TRUNK HINGE ..... 186  
 TRUNK HINGE PADS ..... 186  
 TRUNK LATCH ..... 84, 170  
 TRUNK LID (FIBERGLASS) ..... 203  
 TRUNK LID BASE ..... 84  
 TRUNK LID BASE (INNER) ..... 84  
 TRUNK LID BUMPER ..... 185  
 TRUNK LID HINGES ..... 186  
 TRUNK LID LATCH ..... 84, 170  
 TRUNK LID SEAL ..... 195  
 TRUNK MAT ..... 179  
 TRUNK TOOL COVER (WOOD) ..... 172  
 TUBULAR STRUT ROD ..... 248  
 TURN SIGNAL KIT ..... 78

**U**

U-BOLT ..... 29, 251  
 U-JOINTS ..... 37, 208  
 UPHOLSTERY BUTTONS ..... 133  
 UPHOLSTERY HOG RINGS ..... 165  
 UPPER DOOR SEAL ..... 163

**V**

V-8 EMBLEM, HOOD ..... 98  
 V-8 EMBLEM, LUGGAGE RACK ..... 124  
 V-8 EMBLEM, SHELL ..... 48, 76  
 VACUUM WIPER MOTORS ..... 110, 111  
 VALVE PARTS ..... 35  
 VALVE GUIDE ..... 35  
 VENT GASKET, COWL ..... 138  
 VENT WINDOW EDGE SEAL ..... 183, 184  
 VENT WINDOW ESCUTCHEON ..... 184, 190  
 VENT WINDOW HANDLE ..... 184, 189, 205  
 VENT WINDOW REPAIR KIT ..... 184  
 VENT WINDOW RUBBER ..... 183  
 VENT WINDOW SEAL ..... 183  
 VOLTAGE CUT-OUT ..... 63  
 VOLTAGE REDUCER ..... 63, 207  
 VOLTAGE REGULATOR ..... 63  
 VOLTAGE REGULATOR PAD ..... 63

**W**

WATER PUMPS ..... 51  
 WEATHERSTRIP ADHESIVE ..... 158, 218  
 WEBBING ..... 26  
 WELTING (FENDER) ..... 93  
 WHEEL BEARINGS ..... 8 to 10

WHEEL CYLINDERS (FRONT) ..... 12  
 WHEEL CYLINDERS (REAR) ..... 13  
 WHEEL PARTS ..... 8 to 10, 217  
 WHEEL TRIM RINGS ..... 7  
 WHEEL WELLS ..... 147, 210  
 WINDLACE ..... 162  
 WINDOW CHANNEL (CONVERTIBLE) ..... 152  
 WINDOW CHANNEL (FELT) ..... 155, 156  
 WINDOW CHANNEL (METAL) ..... 157, 159  
 WINDOW CRANK ..... 187-189, 205  
 WINDOW CRANK KNOB ..... 190  
 WINDOW FELT KITS ..... 155, 156  
 WINDOW FRAME (BACK) ..... 151, 213  
 WINDOW FRAME SEAL ..... 152  
 WINDOW GLASS PATTERNS ..... 142  
 WINDOW REGULATORS ..... 161  
 WINDOW RETAINER (DOOR) ..... 155 to 158  
 WINDOW RUBBER (BACK) ..... 184  
 WINDOW RUBBER (VENT) ..... 183, 184  
 WINDOW SEAL (CONVERTIBLE) ..... 152, 153  
 WINDOW SEAL (QUARTER) ..... 184  
 WINDOW SEAL (REAR) ..... 184  
 WINDOW SHADE (BACK) ..... 161  
 WINDOW STOP ..... 158  
 WINDOW VENT, HANDLE ..... 184, 189  
 WINDSHIELD DIVISION BARS ..... 107  
 WINDSHIELD FRAME PARTS ..... 142-144  
 WINDSHIELD FRAMES ..... 142, 213  
 WINDSHIELD FRAME CLIP ..... 143  
 WINDSHIELD GARNISH MOULDING ..... 144  
 WINDSHIELD HANDLE ..... 183  
 WINDSHIELD HARDWARE ..... 143, 144  
 WINDSHIELD HINGE SEAL ..... 182  
 WINDSHIELD POST PAD ..... 144  
 WINDSHIELD REGULATOR HANDLES ..... 183  
 WINDSHIELD REGULATORS ..... 182  
 WINDSHIELD RUBBER ..... 182  
 WINDSHIELD SEAL ..... 182  
 WINDSHIELD SEALER ..... 143  
 WINDSHIELD STANCHION ..... 143, 144  
 WINDSHIELD STUD ..... 134, 144  
 WINDSHIELD SWING ARM ..... 143  
 WINDSHIELD WING NUT ..... 144  
 WINDSHIELD WIPER ARMS ..... 112, 205  
 WINDSHIELD WIPER MOTORS ..... 110, 111  
 WINDSHIELD WIPER PARTS ..... 110 to 113  
 WINDSHIELD WIPER TOWERS ..... 113  
 WINDING BRACKETS ..... 121  
 WINDING BRACKET PADS ..... 121  
 WINDING TENSION SPRING ..... 134  
 WING TIPS (BUMPER) ..... 120  
 WIPER ARMS & BLADES ..... 112, 205  
 WIPER ARM NUT ..... 111  
 WIPER MOTORS ..... 110, 111  
 WIPER SHAFT SEAL ..... 112  
 WIPER SWITCH ..... 112  
 WIPER TOWER ..... 113  
 WIPER TOWER PADS ..... 112  
 WIRE CLAMP ..... 64  
 WIRE CLIP ..... 69  
 WIRE CONNECTOR ..... 69  
 WIRE LOOM ..... 69, 72, 213  
 WIRE LOOM GROMMET ..... 68  
 WIRE PER FOOT ..... 69  
 WIRING BOARDS (STREET ROD) ..... 262  
 WIRING, CLOCK LIGHT ..... 66  
 WIRING, COIL ..... 67  
 WIRING, CONVERTIBLE TOP ..... 66  
 WIRING, COWL LIGHT ..... 67  
 WIRING, DASH ..... 68, 206  
 WIRING, DOME LIGHT ..... 69  
 WIRING, ENGINE ..... 66, 67  
 WIRING, HEADLAMP ..... 67  
 WIRING, HIGH BEAM JEWEL ..... 84  
 WIRING, HORN ..... 86  
 WIRING, HORN BUTTON ..... 20  
 WIRING, LICENSE LIGHT ..... 69  
 WIRING, OVERDRIVE ..... 69  
 WIRING, PARKING LIGHT ..... 77  
 WIRING, SPARK PLUG ..... 71  
 WIRING SYSTEM (STREET ROD) ..... 206, 207  
 WIRING, TAIL LIGHT ..... 69  
 WISHBONE SPLITTER ..... 206  
 WOOD, FLOOR BOARD ..... 172  
 WOOD, HEADER ..... 170, 171  
 WOOD, PACKAGE TRAY ..... 171  
 WOOD, ROOF RIB ..... 171  
 WOOD, SEAT FRAME ..... 170  
 WOOD, WINDOW FRAME ..... 171  
 WOOD, WINDSHIELD STRIP ..... 171  
 WORM GEAR (STEERING) ..... 17

**X**

X-MEMBER SUPPORT ..... 212

# FRAME



### BODY TO FRAME SHIMS

ALL YEARS

B-5000-SHK (PKG. OF 10)

4.95

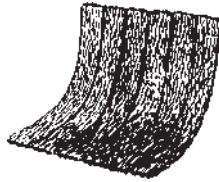

### BODY-TO-FRAME WEBBING - 1/16"

1/16" X 1" WIDE  
B-5010-A (25' ROLL)

40.00

1/16" X 1 1/2" WIDE  
B-5010-B (25 Ft. ROLL)

40.00

1/16" X 2" WIDE  
B-5020-B (25 Ft. ROLL)

45.00

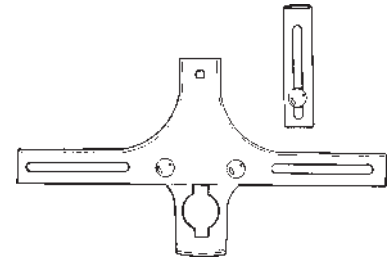

### FRONT LICENSE HOLDER

1932 PASSENGER  
(BLACK)

B-5034-B EACH  
(STAINLESS)

30.00

B-5034-SS EACH

35.00

1933-36 PASSENGER & COMMERCIAL  
(BLACK)

40-5034-B EACH  
(STAINLESS)

30.00

40-5034-SS EACH

35.00

1937-38 PASSENGER; 39 STD.; 37-39  
PICKUP

(BLACK)

78-5034-B EACH  
(STAINLESS)

30.00

78-5034-SS EACH

35.00

1939-40 PASSENGER; 40-41 COMM.  
(BLACK)

81A-5034-B EACH  
(STAINLESS)

30.00

81A-5034-SS EACH

35.00

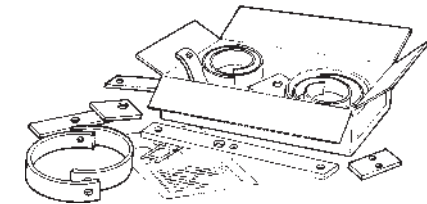

### BODY TO FRAME MOUNTING PAD KITS

EACH KIT IS TAILORED FOR SPECIFIC  
YEARS. SUPER QUALITY MATERIALS ARE  
USED THROUGHOUT.

1935-36 PASSENGER; 19 PC. DIE CUT  
48-5001 KIT 75.00

1937-40 PASSENGER; 34 PC, MOLDED  
RUBBER  
78-5001 KIT 45.00

1940 CONVERTIBLE  
01A-5001 KIT 50.00

1941 PASSENGER; 19 PC. MOLDED  
RUBBER  
11A-5001 KIT 40.00

1941 CONVERTIBLE  
11A-5001-B KIT 40.00

1942-48 PASSENGER; 18 PC. MOLDED  
RUBBER  
21A-5001 KIT 45.00

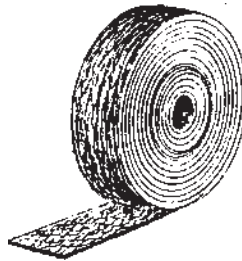

### BODY-TO-FRAME WEBBING - 1/8"

1/8" X 1 1/2" WIDE  
B-5010-D (25 Ft. ROLL)

45.00

1/8" X 2" WIDE  
B-5010-E (25 Ft. ROLL)

45.00

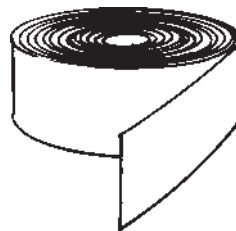

### BODY-TO-FRAME WEBBING - 1/8" WITH PRESSURE SENSITIVE ADHESIVE AND RELEASE PAPER.

1/8" X 1 1/2"  
B-5015-D (25 Ft. ROLL)

50.00

1/8" X 2"  
B-5020-D (25 Ft. ROLL)

50.00

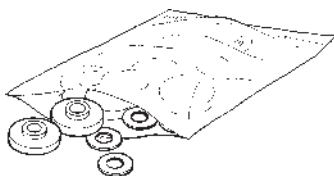

### RUNNING BOARD TO FRAME GROMMETS

1942-48

21A-16452-S 48 PC. KIT

24.00

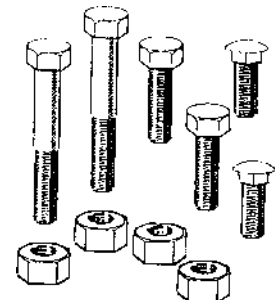

### BODY-TO-FRAME BOLT KITS

1937-40 CLOSED CARS  
78-5000-HK 126 PC KIT

25.00

1941-48 PASSENGER  
51A-5000-HK 44 PC KIT

25.00



# FRAME (CONT'D)

# BATTERY BOX



### FRAME SPREADER BARS

#### FRONT CROSSBAR BETWEEN FRAME HORNS - 1932

POLISHED STAINLESS B-5041-SS EACH	95.00
POLISHED STAINLESS "V" SHAPED B-5041-V EACH	140.00
UNPLATED STEEL B-5041 EACH	75.00

#### REAR CROSSBAR BETWEEN FRAME HORNS - 1932

POLISHED STAINLESS B-18575-SS EACH	130.00
UNPLATED STEEL B-18575 EACH	95.00

SPREADER BARS NOW AVAILABLE WITH LED'S BUILT IN!! CALL FOR INFORMATION

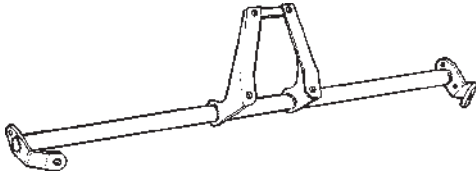

#### REAR FRAME SPREADER BAR 1933-34

WITH SPARE CARRIER BRACKET 40-5035-A EACH	INQUIRE
NO REAR MOUNTED SPARE 40-5035-B EACH	125.00
SEDAN DELIVERY 40-5035-SD EACH	INQUIRE
1934 VICTORIA 40-5035-V EACH	INQUIRE

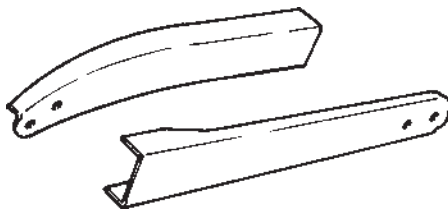

#### FRAME HORN EXTENSIONS

1932 FRONT 18-5158-F PAIR	85.00
1932 REAR 18-5158-R PAIR	85.00
1933-34 FRONT 40-5158-F PAIR	125.00
1933-34 REAR 40-5158-R PAIR	125.00

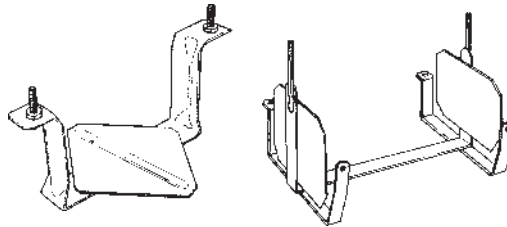

#### BATTERY SUPPORT ASSEMBLY

1932 PASSENGER & COMM.; 32-34 TRUCK B-5151 EACH	60.00
1933-34 PASSENGER & COMMERCIAL 40-5151 EACH	40.00

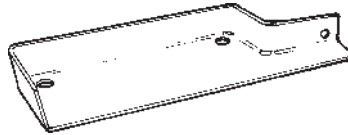

#### BATTERY BOX LOWER FRAME

1935-36 PASSENGER & COMMERCIAL 48-5153 EACH	65.00
---	-------

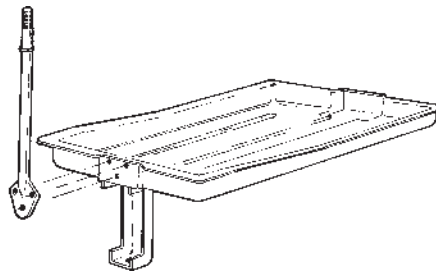

#### BATTERY TRAY

1939 DELUXE CLOSED CARS TRAY & HOLD DOWN KIT 91A-5154-A EACH	165.00
OPEN CARS & STATION WAGON 91A-5154-B EACH	INQUIRE

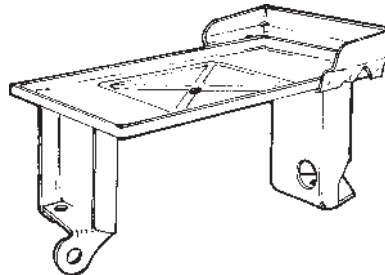

#### BATTERY SUPPORT ASSEMBLY

1940 PASSENGER; 40-41 COMM. 01A-5151 EACH	50.00
---	-------



#### BATTERY TRAY

1941-48 PASSENGER 11A-5151 (11A-10732) EACH	85.00
---	-------

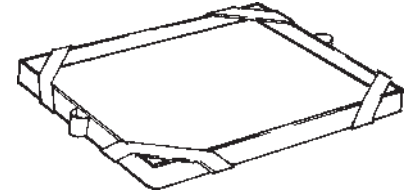

#### BATTERY HOLD-DOWN FRAME

1932 ALL A-5163-FR EACH	10.00
1933-48 ALL EXCEPT 39 DELUXE 40-5165-HD EACH	20.00

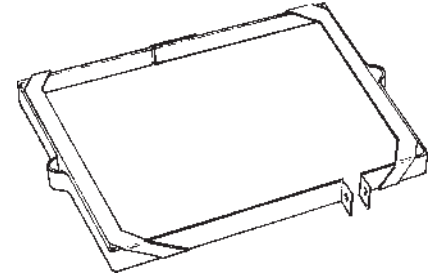

1939 DELUXE 91A-5165 EACH	49.95
---------------------------	-------

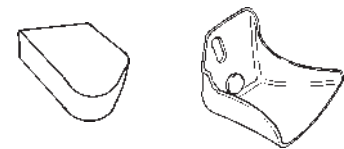

#### BATTERY HOLD-DOWN BRACKET

1939 DELUXE 91A-5171 EACH	19.00
1940 PASSENGER; 40-41 PICKUP 01A-5171 EACH	8.00

#### BATTERY HOLD-DOWN PAD

1940 PASSENGER; 40-47 COMM. 01A-5158 EACH	3.00
---	------



#### BATTERY DEFLECTOR

KEEPS WATER FROM SPLASHING UP ON BATTERY. 1935-36 48-700374 EACH	7.50
--	------

# EXHAUST SYSTEM

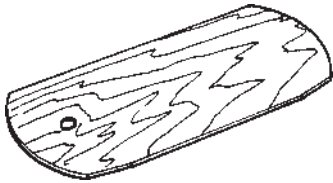

**1933-34 BATTERY FLOOR COVER**  
40-55336 EACH 8.00

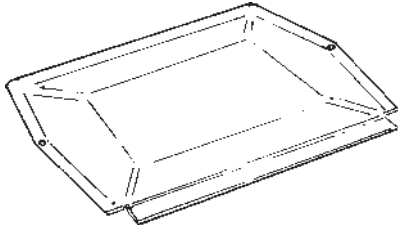

**BATTERY FLOOR COVER**  
STAMPED METAL  
1935-36  
48-700336 EACH 56.25

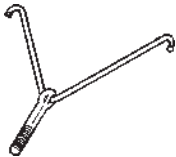

**BATTERY HOLD-DOWN Y-BOLT**  
1935-36 PASSENGER & COMMERCIAL  
48-5172 EACH 15.00



**BATTERY HOLD-DOWN J-BOLTS**  
1941-48 PASSENGER; 41-48 COMM.  
11A-5175 EACH 4.50

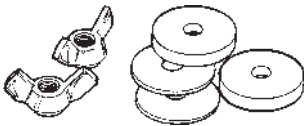

**BATTERY HOLD-DOWN NUT & WASHER KIT**  
1941-48 PASSENGER; 41-47 PICKUP  
11A-5179-S KIT 10.00

**FOR MORE BATTERY BOXES SEE PAGE 210 IN OUR STREET ROD SECTION**

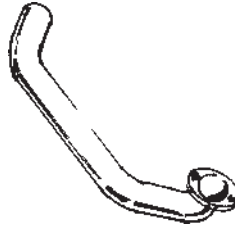

**CROSSOVER PIPE**

1932 V8 PASSENGER & COMMERCIAL  
18-5267 EACH 55.00

1933-34 V8 PASSENGER & COMMERCIAL  
40-5267 EACH 39.95

1935-36 PASSENGER & COMMERCIAL  
68-5267 EACH 39.95

1937-41 PASSENGER & COMMERCIAL  
78-5267 EACH 39.95

1937-41 TRUCK, 90 & 100 HP  
79-5267 EACH 39.95

1942-48 PASSENGER  
51A-5267 EACH 39.95

1942-47 V8 COMMERCIAL  
59C-5267 EACH 39.95



**CROSSOVER CLAMP**

1932-42  
18-5251 EACH 7.50



**MUFFLER - U.S.A.**

1932-34 V8 PASSENGER & COMMERCIAL  
48-5230-C EACH 65.00

1935-38 PASSENGER & COMMERCIAL  
48-5230-B EACH 65.00

1939-40 PASSENGER & COMMERCIAL  
91A-5230-B EACH 65.00

1942-48 PASSENGER  
2GA-5230 EACH 65.00

1942-47 COMMERCIAL  
21C-5230 EACH 65.00

**ASK ABOUT V8 60**

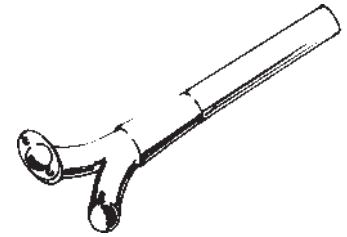

**EXHAUST PIPE**

1932 V8 PASSENGER & COMMERCIAL  
18-5245 EACH INQUIRE

1933-34 V8 PASSENGER & COMMERCIAL  
40-5245 EACH 75.00

1935-36 PASSENGER & COMMERCIAL  
48-5245 EACH 75.00

1937-40 PASSENGER; 40-41 PICKUP  
91A-5245-A EACH 75.00

1941 PASSENGER & COMMERCIAL  
11A-5245 EACH 125.00

1938-41 TRUCK  
81T-5245 EACH 75.00

1942-48 PASSENGER  
21A-5245 EACH 75.00

1942-52 TRUCK  
7RC-5245 EACH 75.00



**TAIL PIPE**

1932 V8 PASSENGER & COMMERCIAL  
2 PIECE  
B-5255-S PAIR 68.95

1933-34 V8 PASSENGER & COMMERCIAL  
2 PIECE  
40-5255-S PAIR 68.95

1935-38 PASSENGER & COMMERCIAL  
48-5255 EACH 68.95

1939-40 PASSENGER & COMMERCIAL  
91A-5255 EACH 68.95

1942-48 PASSENGER  
21A-5255 EACH 68.95

**ASK ABOUT SHOW QUALITY EXHAUST SYSTEMS**

# EXHAUST SYSTEM (CONT'D.)

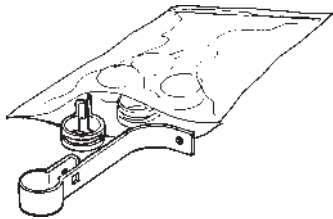

## EXHAUST BRACKETS & CLAMPS - U.S.A.

COMPLETE EXHAUST SYSTEM HANGING KITS.

1932 V8 PASSENGER & COMMERCIAL B-5200 KIT	35.00
1933-34 PASSENGER & COMMERCIAL 40-5200 KIT	35.00
1935-38 PASSENGER & COMMERCIAL 48-5200 KIT	35.00
1939-41 PASSENGER & COMMERCIAL 11A-5200 KIT	INQUIRE
1938-41 TRUCK 81T-5200 KIT	INQUIRE
7RC-5200 KIT	INQUIRE

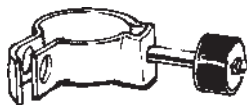

## TAIL PIPE MOUNTING BRACKETS

FRONT BRACKET 1939-41 11A-5259 EACH	12.50
REAR BRACKET 1939-41 99A-5261 EACH	10.00
EXHAUST/MUFFLER CLAMP 1935-46 48-5270 EACH	5.00

## INQUIRE ABOUT OTHER BRACKETS

**ASK ABOUT TRUCK SHACKLES 1935-48**

# SPRING



**WE HAVE N.O.S. SPRINGS PLEASE INQUIRE**

## FRONT SPRING - U.S.A.

1932-34 PASSENGER & COMMERCIAL 40-5310 EACH	165.00
1942-48 1/2 TON COMMERCIAL 21C-5310-B EACH (2 REQ'D.)	155.00

## BLACK SPRING POLY ANTI-SQUEEK

1932-34 PASSENGER & COMMERCIAL FRONT 1 3/4" WIDE U-5310-P KIT	20.00
1935-48 PASSENGER & COMMERCIAL FRONT 2" WIDE U-5310-PB KIT	14.00
1928-48 REAR 2 1/4" WIDE U-5560-PA KIT	20.00

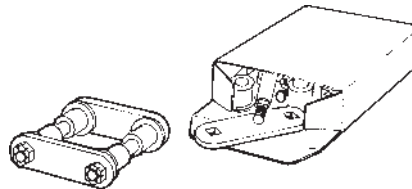

## SPRING SHACKLE KIT

ORIGINAL STYLE - COMPLETE FOR ONE SPRING.

## FRONT SHACKLE KIT

1932-34 PASSENGER & COMMERCIAL B-5304 KIT	30.00
1932-34 1 TON TRUCK BB-5715-S KIT	47.95
1935-40 PASSENGER & COMMERCIAL 48-5304 KIT	24.50
1941 PASSENGER 11A-5304 KIT	24.50
1942-48 PASSENGER 21A-5304 KIT	30.00

## REAR SHACKLE KIT

1932-34 PASSENGER & COMMERCIAL B-5630 KIT	30.00
1935-40 PASSENGER & COMMERCIAL 48-5630 KIT	26.50
1941 PASSENGER 11A-5630 KIT	24.50
1942-48 PASSENGER 21A-5630 KIT	27.50

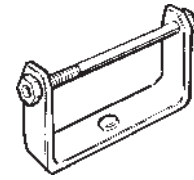

## SPRING CLAMPS - U.S.A.

### FRONT SPRING CLAMP

1932-34, 12 LEAF A-5330-B EACH	2.95
1932-37, 10 LEAF 40-5330-A EACH	2.95

### REAR SPRING CLAMP

1932-34, 7,8, OR 10 LEAF B-5724-A EACH	6.25
---	------

FOR SPRING LINERS SEE PAGE #

## 1942-47 PICKUP SHACKLE PARTS

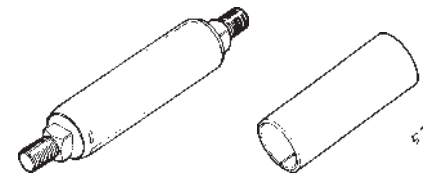

### FRONT SPRING SHACKLE BRACKET BUSHING

1942-47 COMMERCIAL (2 REQ'D) 21C-5344 EACH	5.00
---	------

### MAIN LEAF BUSHING

1942-47 COMMERCIAL (4 REQ'D) 21C-5348 EACH	5.00
---	------

### FRONT SPRING SHACKLE BOLT

1942-47 COMMERCIAL (6 REQ'D) 21C-5465 EACH	8.00
---	------

### FRONT SPRING INNER SHACKLE BAR

1942-47 COMMERCIAL (2 REQ'D) 21C-5468 EACH	3.95
---	------

### FRONT SPRING OUTER SHACKLE BAR

1941-47 COMMERCIAL (2 REQ'D) 21C-5469 EACH	3.95
---	------

### REAR SPRING HANGER PIN

1942-47 COMMERCIAL (6 REQ'D) 21C-5780 EACH	5.95
---	------

### REAR SPRING MAIN LEAF BUSHING

1941-47 COMMERCIAL (4 REQ'D) 21C-5781 EACH	7.50
---	------

### REAR SPRING SHACKLE HANGER BUSHING

1942-47 COMMERCIAL (2 REQ'D) 21C-5791 EACH	7.50
1938-60 3/4 & 1 TON 61-5791 EACH	7.50
1932-38 TRUCKS BB-5791 EACH	7.50

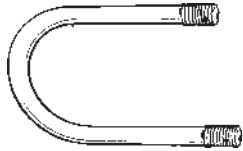

**FRONT SPRING U-BOLT**

1932-34 PASSENGER & COMMERCIAL  
SQUARE TOP 4" DEPTH  
B-5455 EACH 10.00  
B-5455-S SET 18.50  
ROUND TOP 5" DEPTH  
A-5455-S SET 18.50

1935-41 PASSENGER & COMMERCIAL  
48-5455 EACH 12.50

1942-48 PASSENGER  
51A-5455 EACH 10.00

1942-47 1/2 TON  
21C-5455 EACH 12.50

1942-47 2 TON TRUCK  
59T-5455 EACH 12.50

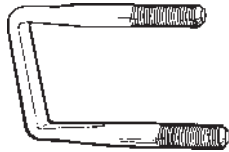

**REAR SPRING U-BOLT**

1932-41 PASSENGER & COMMERCIAL  
B-5705 EACH 10.00  
B-5705-S SET 19.50

1941-48 PASSENGER  
51A-5705 EACH 10.00

1942-48 1/2 TON  
21C-5701-C EACH 10.00

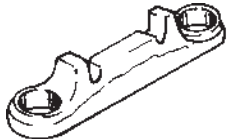

**SPRING CLIP BAR**

FRONT  
1935-48 PASSENGER; 35-41 COMM.  
11A-5458 EACH 10.00

REAR  
1932-41 PASSENGER; SOME COMM.  
B-5710-C EACH 11.00

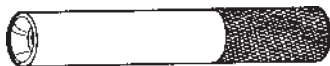

**SHACKLE DRIVER**

1932-48  
X-5465 EACH 20.00

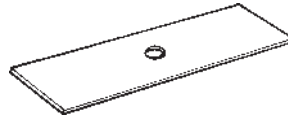

**FRONT & REAR SPRING ANTI-SQUEAK PAD**

1932-34 PASSENGER & COMMERCIAL  
48-5599 EACH 2.95

1935-48 PASSENGER & COMMERCIAL  
11A-5599 EACH 2.95

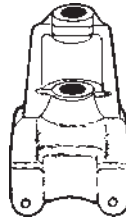

**SPRING SHACKLE BRACKET**

1942-47 COMMERCIAL FRONT OR REAR  
21C-5775 EACH 39.95



**REAR SPRING HANGER BRACKET**

1942-47 COMMERCIAL  
21C-5776 EACH 39.95



**REAR SPRING ASSEMBLY**

1942-48 1/2 TON PICKUP  
21C-5560 EACH (2 REQ'D.) 295.00



**STABILIZER BAR**

1940-41 PASSENGER  
01A-3530 EACH INQUIRE



**STABILIZER BAR BUSHING**

1940-41 PASSENGER  
11A-3558-A PAIR 10.00

1942-48 PASSENGER  
21A-5484-A PAIR 10.00

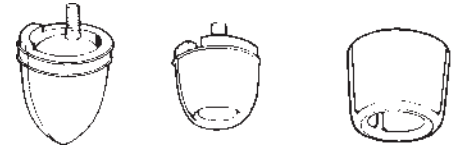

**REAR AXLE BUMPERS**

1932 PASSENGER & COMMERCIAL  
B-5783 EACH 10.00

1932-39 2 TON TRUCK  
BB-5783 EACH 10.00

1933-34 PASSENGER & COMMERCIAL  
40-5783 EACH 10.00

1935-38 PASSENGER & COMMERCIAL  
48-5783 EACH 10.00

1939-40 PASSENGER & COMMERCIAL  
91A-5783 PAIR 30.00

1941-48 PASSENGER & COMMERCIAL  
21A-3020 EACH 10.00

**USE OUR 800 NUMBER OR  
FAX NUMBER FOR  
PLACING YOUR ORDER!**

# ENGINE

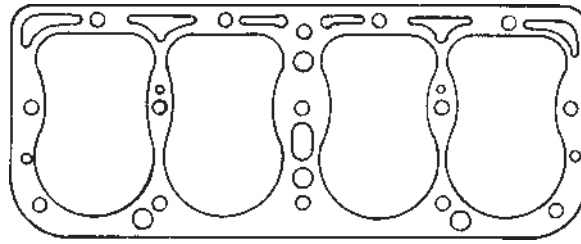

## HEAD GASKETS

1932-34 4 CYLINDER B-6051-C EACH B-6051-G EACH	50.75 42.00	1939-42 3 3/16" BORE LARGE WATER OPENINGS 09A-6051 EACH	INQUIRE	1947-51 SERIES H 6 CYLINDER 7HA-6051-C EACH	63.00
1932-37 21 STUD V8 40-6051-C EACH 40-6051-G EACH	45.50 38.50	1939-48 100 H.P. V8 3 3/16" BORE SMALL WATER OPENINGS 59A-6051-C EACH 59A-6051-G EACH	47.50 35.00	1939-48 BIG BORE COPPER 99A-6051-C EACH 99A-6051-G EACH	54.25 49.00
1938-42 24 STUD V8 (85 H.P.) 3 1/16" BORE LARGE WATER OPENINGS 91A-6051-C EACH 91A-6051-G EACH	50.75 35.00	1937-40 V8 60 52-6051-G EACH	45.50	1949-53 V8 RIGHT HAND 8BA-6051-GRH EACH 8BA-6051-CRH EACH	35.00 47.25
1938-42 24 STUD V8 (85 H.P.) 3 1/16" BORE SMALL WATER OPENINGS 41A-6051 EACH	INQUIRE	1940-41 4 CYLINDER 9N-6041 EACH	INQUIRE	1949-53 V8 LEFT HAND 8BA-6083-GLH EACH 8BA-6083-CLH EACH	35.00 47.25
		1941-47 SERIES G 6 CYLINDER 1GA-6051 EACH	INQUIRE		

**C SUFFIX DENOTES COPPER  
G SUFFIX DENOTES GRAPHITE**

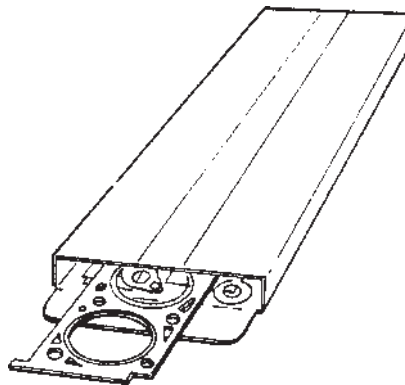

## COMPLETE ENGINE GASKET SET

1932-34 4 CYLINDER B-6008-C SET B-6008-G SET	110.25 94.50	1939-48 BIG BORE 99A-6008-C SET 99A-6008-G SET	166.25 159.25
1932-38, 21 STUD V8 40-6008-C SET 40-6008-G SET	178.50 164.50	1941-47 SERIES G 6 CYLINDER 1GA-6008 SET	INQUIRE
1937-40 V8 60 74-6008-G SET	183.75	1947-48 SERIES H 6 CYLINDER 7HA-6008-C SET	148.75
1938-42, 24 STUD V8, LG. HOLE 91A-6008-C SET 91A-6008-G SET	164.50 117.25	1941-42 4 CYLINDER 1NC-6008- SET	INQUIRE
1938-48, 24 STUD V8, SMALL HOLE 59A-6008-C SET 59A-6008-G SET	138.25 110.25	1949-53 V8 8BA-6008-C SET 8BA-6008-G SET	131.25 103.25



**FUEL PUMP PUSH ROD BUSHING**

1932-48 V8 ALL  
18-6025 EACH

8.00



**ENGINE PAINT**

12 OZ. SPRAY CAN - USUALLY  
REQUIRES 2-3 CANS

**ANTIQUE FORD GREEN**

1932-36  
M-200 EACH

7.00

**ANTIQUE FORD BLUE**

1942-48 PASSENGER; 41-48 COMM.  
M-202 EACH

7.00

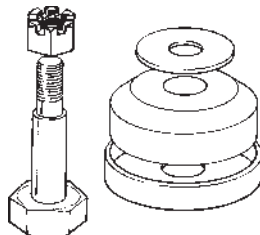

**MOTOR MOUNTS**

1932-36 V8 FRONT; 2 SETS REQUIRED  
B-6038-K SET 25.00

1937-41 V8; 4 SETS REQUIRED  
1942-48 V8; 2 SETS REQUIRED  
78-6038-K SET 25.00



**CYLINDER SLEEVE**

1932-34 4 CYLINDER  
B-6055 EACH INQUIRE

ORIGINAL STYLE THIN WALL U.S.A.  
QUALITY SLEEVE

1932-41 V8 (3 1/16 BORE) 0.040" WALL  
91A-6055 EACH 75.00

1939-53 CAST WALL, 3 3/16" BORE  
21A-6055 EACH 75.00

OTHERS AVAILABLE , INQUIRE



**CYLINDER HEAD (N.O.S. CAST IRON)**

1938-42 85 H.P.  
81A-6050/51 PAIR ONLY INQUIRE



**DIP STICK TUBE BOSS**

INCLUDE GASKET & MOUNTING RIVETS  
1935-46  
48-6751 KIT 20.00

1947-48  
59A-6751 KIT 25.00



**CHROME CYLINDER HEAD NUT COVERS**

1932-48 ALL  
CNC-6062-AS 50 PC. SET 35.00

**CHROME INTAKE MANIFOLD NUT COVERS**

1932-48 ALL  
IN-6520-C 20 PC. SET 15.00

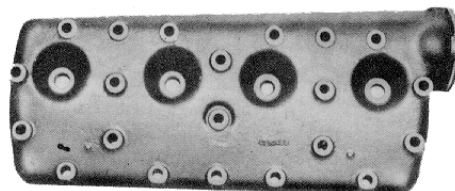

**CYLINDER HEADS - ALUMINUM  
EXACT REPRODUCTIONS**

1933 V8  
40-6049/50 PAIR INQUIRE

1934 V8 (NON SCRIPT)  
40-6049/50-A PAIR INQUIRE  
1934 V8 (SCRIPT)  
40-6049/50-A2 PAIR INQUIRE

1935-36  
48-6049/50 PAIR INQUIRE

1936 V8 (SPECIAL ORDER)  
68-6049/50 PAIR INQUIRE

1932-36 V8 (EDDIE MEYER FINNED)  
EM-6049/50 PAIR INQUIRE



**CYLINDER HEAD WASHER - U.S.A.**

1932-48 ALL (CAD PLATED)  
B-6063 EACH .45



**CYLINDER HEAD NUT - U.S.A.**

1932-48 ALL (CAD PLATED)  
B-6064 EACH .45

**USE OUR TOLL FREE  
ORDER NUMBER:  
1-800-532-1932**

**ASK ABOUT V8 60 PARTS**

# ENGINE (CONT'D.)

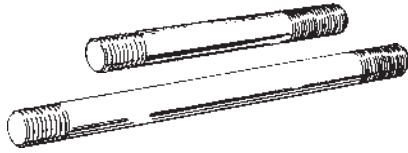

## CYLINDER HEAD STUD

1932-37, 10 REQUIRED 1938-48, 16 REQUIRED 2.34" LONG 40-6065 EACH	2.75
1942-48, 4 REQUIRED 2.78" LONG 18-6066 EACH	2.50
1932-36, 10 REQUIRED 1937, 8 REQUIRED 1938-41, 4 REQUIRED 2.90" LONG 40-6066 EACH	2.00
1932-36, 22 REQUIRED 3.59" LONG 40-6067 EACH	3.00
1937, 24 REQUIRED 1938-48, 28 REQUIRED 1941-47 6 CYLINDER, 31 REQUIRED 3.09" LONG 48-6067 EACH	2.25
1938-44, 1 REQUIRED 1941-47 6 CYLINDER, 2 REQUIRED 3.25" LONG 91A-6067 EACH	2.00

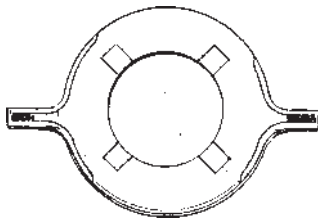

## REAR ENGINE SUPPORT (REAR TRANSMISSION MOUNT) U.S.A. REBUILT

1932 PASSENGER & COMMERCIAL B-5089 EACH	64.00
1933-34 PASSENGER & COMMERCIAL 40-5089-B EACH	61.50
1935-36 PASSENGER & COMMERCIAL 48-5089 EACH	60.00
*FOR REBUILT ADD CORE CHARGE	35.00



## REAR ENGINE SUPPORT

1942-48 PASSENGER; 42-47 COMM. 21A-6068-A EACH	40.00
---	-------

## PISTONS

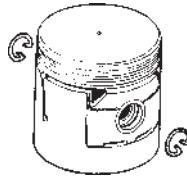

### 1932-36 V8, FLAT TOP, 3 RING 3 1/16" DIAMETER

STANDARD 40-6108-AS SET	325.00
.010 OVER 40-6108-BS SET	325.00
.020 OVER 40-6108-CS SET	325.00
.030 OVER 40-6108-DS SET	325.00
.040 OVER 40-6108-ES SET	325.00
.060 OVER 40-6108-FS SET	325.00

### 1935-42 V8, DOME TOP, 4 RING 3 1/16" DIAMETER

STANDARD 01T-6108-AS SET	335.00
.010 OVER 01T-6108-BS SETS	
.020 OVER 01T-6108-CS SET	335.00
.030 OVER 01T-6108-DS SET	335.00
.040 OVER 01T-6108-ES SET	335.00
.060 OVER 01T-6108-FS SET	335.00

### 1939-48 V8, DOME TOP, 4 RING

STANDARD 3 3/16" DIAMETER  
(USE 8BA RINGS WITH THESE PISTONS.)

STANDARD 8BA-6108-AS SET	295.00
.010 OVER 8BA-6108-BS SET	295.00
.020 OVER 8BA-6108-CS SET	295.00
.030 OVER 8BA-6108-DS SET	295.00
.040 OVER 8BA-6108-ES SET	295.00
.060 0OVER 8BA-6108- FS SET	295.00
.080 OVER 8BA-6108-GS SET	295.00



## PISTON RING SET

SOLD ONLY AS FULL ENGINE SETS.

### 1932-42 V8, 3 RING, 3 1/16"

STANDARD 81A-6149-AS SET	75.00
.010 81A06149-BS SET	75.00
.020 81A-6149-CS SET	75.00
.030 81A-6149-DS SET	75.00
.040 81A-6149-ES SET	75.00
.060 81A-6149-FS SET	75.00

### 1932-42 V8, 4 RING, 3 1/16"

STANDARD 01T-6149-AS SET	88.00
.010 01T-6149-BS SET	88.00
.020 01T-6149-CS SET	88.00
.030 01T-6149-DS SET	88.00
.040 01T-6149-ES SET	88.00
.060 01T-6149-FS SET	88.00

### 1939-48, V8, 4 RING, 3 3/16" FOR ORIGINAL 09T PISTONS.

STANDARD 29A-6149-AS SET	95.00
.010 29A-6149-BS SET	95.00
.020 29A-6149-CS SET	95.00
.030 29A-6149-DS SET	95.00
.040 29A-6149-ES SET	95.00
.060 29A-6149-FS SET	95.00

## MERCURY 49-53 AVAILABLE

**PISTON RING SET (CONT'D)**

**1939-53 V8, 4 RING, 3 3/16" STANDARD**  
USE WITH 8BA PISTONS.

STANDARD 8BA-6149-AS SET	85.00
.010 8BA-6149-BS SET	85.00
.020 8BA-6149-CS SET	85.00
.030 8BA-6149-DS SET	85.00
.040 8BA-6149-ES SET	85.00
.060 8BA-6149-FS SET	85.00
.080 8BA-6149-GS SET	85.00

**1941-47, G SERIES 6 CYLINDER RINGS**

STANDARD 2GT-6149-AS SET	85.00
.020 2GT-6149-CS SET	85.00
.030 2GT-6149-DS SET	85.00
.040 2GT-6149-ES SET	85.00
.060 2GT-6149-FS SET	85.00

**1947-51 H SERIES 6 CYLINDER RINGS**

STANDARD 7HA-6149-AS SET	85.00
.020 7HA-6149-CS SET	85.00
.030 7HA-6149-DS SET	85.00
.040 7HA-6149-ES SET	85.00
.060 7HA-6149-FS SET	85.00



**CAMSHAFT**

1935-38, V8 48-6250 EACH	125.00
NOTE: 48-6250 WILL FIT 1939-41 BY USING 48-6256 TIMING GEAR.	
1942-48, V8 21A-6250 EACH	125.00
1941-47 G SERIES 6 CYLINDER 5GA-6250 EACH	125.00

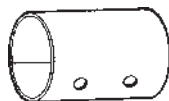

**CONNECTING ROD BUSHING**

1928-34 4 CYL B-6207 EACH	1.75
1932-41 V8 18-6207 EACH	2.50
1942-48 V8 21A-6207 EACH	2.50
1941-51 6 CYLINDER G & H SERIES 2GA-6207 EACH	3.50

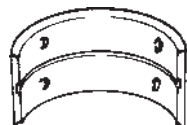

**CONNECTING ROD BEARINGS**

<b>1932-38 V8 WITH FLANGE</b> STANDARD CRANKSHAFT 1.998" 48-6211-AS SET	199.00
.010 48-6211-CS SET	250.00
.020 48-6211-MS SET	260.00
.030 48-6211-QS SET	260.00
.040 48-6211-JJ SET	260.00
<b>1938-42 V8, WITHOUT FLANGE</b> STANDARD CRANKSHAFT: 1.998".	
STANDARD 81A-6211-AS SET	110.00
.010 81A06211-CS SET	140.00
.020 81A-6211-MS SET	140.00
.030 81A-6211-QS SET	140.00
.040 81A-6211-KK SET	140.00
<b>1939-48 V8</b> STANDARD CRANKSHAFT: 2.138".	
STANDARD 99T-6211-AS SET	110.00
.010 99T-6211-KS SET	140.00
.020 99T-6211-MS SET	140.00
.030 99T-6211-QS SET	180.00
.040 99T-6211-YS SET	180.00

**CONNECTING ROD BEARINGS (CONT'D)**

<b>1941-47, 6 CYLINDER G SERIES</b>	
STANDARD 1GA-6211-A SET	96.50
.010 1GA-6211-E SET	96.50
.020 1GA-6211-G SET	96.50
.030 1GA-6211-H SET	96.50
<b>1947-48, 6 CYLINDER H SERIES</b>	
.002 7HA-6211-B SET	96.50
.010 7HA-6211-C SET	96.50
.020 7HA-6211-D SET	96.50
.030 7HA-6211-E SET	96.50



<b>CONNECTING ROD NUT</b> 1932-48, V8, 6 CYLINDER 1GA-6212 EACH	.75
---	-----

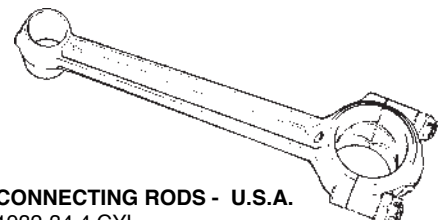

<b>CONNECTING RODS - U.S.A.</b> 1932-34 4 CYL STD, .010,.020,.030, SPECIFY B-6200 EACH EXCHANGE	75.00
<b>CORE CHARGE \$50.00</b> 1932-42 V8, 90 H.P. 21A-6200 EACH, EXCHANGE	45.00
1939-48 V8, 100 H.P. 59A-6200 EACH, EXCHANGE	45.00
1941-47, G SERIES 6 CYLINDER 2GA-6200 EACH	36.95
1947-51, H SERIES 6 CYLINDER 7HA-6200 EACH	36.95
<b>CORE CHARGE</b>	<b>15.00</b>

**ASK ABOUT N.O.S. RODS**

**ASK ABOUT V8-60  
AND 6 CYLINDER**



# ENGINE (CONT'D.)



## CAMSHAFT OIL PUMP DRIVE GEAR

1932-41 V8 (ROUND INSIDE)  
18-6254-A EACH 5.95

1932-53 V8 (FLAT INSIDE)  
18-6254-B EACH 5.95



TIMING GEAR LOCK RING  
1935-48  
91A6258 EACH 3.75

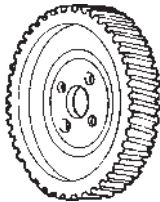

## CAMSHAFT TIMING GEAR - U.S.A.

1932-35 (PRESS-ON)  
18-6256 EACH 38.95

1935-41 (PRESS-ON)  
48-6256 EACH 47.95

1935-48 (BOLT-ON) ALUMINUM  
91A-6256 EACH 64.95

1935-48 FIBRE (BOLT-ON)  
11A-6256 EACH 47.95

1941-47, 6 CYLINDER G SERIES  
1GA-6256 EACH 37.95

1947-51, 6 CYLINDER H SERIES  
7HA-6256 EACH 37.95



## CAM BEARINGS

SOLD ONLY AS FULL ENGINE SETS.

1932-48 V8 STANDARD  
01A-6261/62-AS SET 24.95

1932-48 V8 .010  
01A-6261/62-BS SET (LIMITED QUAN) 29.95

1941-47 G SERIES 6 CYLINDER  
(4 PER SET)  
1GA-6262 SET 65.00

1947-51 H SERIES 6 CYLINDER  
(4 PER SET)  
7HA-6262 45.00



## DISTRIBUTOR TO CAMSHAFT ADAPTER

(42-48 CAM TO 32-41 DISTRIBUTOR)  
11A-6280 EACH 14.95

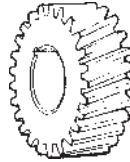

## CRANKSHAFT STEEL GEAR

1932-34 4 CYLINDER  
B-6306 EACH 16.95

1932-36 V8, 28 TEETH  
18-6306 EACH 35.00

1935-48 V8, 22 TEETH  
48-6306 EACH 24.95

1941-47 6 CYLINDER G SERIES  
1GA-6306 EACH 24.95

1947-51 6 CYLINDER H SERIES  
7HA-6306 EACH 24.95

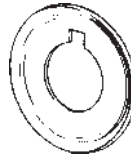

## CRANKSHAFT OIL SLINGER

1932-38 V8  
40-6310-A EACH 1.95

1939-48 V8  
81A-6310 EACH 1.95

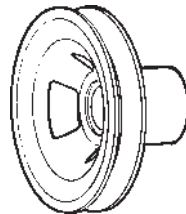

## CRANKSHAFT PULLEY

1932 4 CYLINDER  
B-6312 EACH 32.50

1933-34 4 CYLINDER  
46-6312 EACH 65.00

1932-38 V8  
18-6312 EACH 65.00

1939-41 PASSENGER & COMMERCIAL  
91A-6312 EACH 75.00

1942-48 PASSENGER; 42-47 COMM.  
21A-6312 EACH 105.00

TRUCK PULLEYS AVAILABLE - INQUIRE

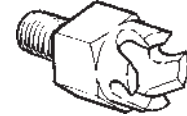

## CRANKSHAFT PULLEY NUT (RATCHET)

1932-38, ALL  
B-6319 EACH 9.95

1939-48, ALL  
81A-6319 EACH 7.95

WASHER  
81A-6332 EACH 2.00

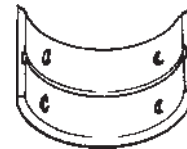

## CRANKSHAFT MAIN BEARING SET

### 1936-38 V8

68-6330-AS SET STD. 90.00

68-6330-CS SET .010 115.00

68-6330-FS SET .020 115.00

68-6330-NS SET .030 115.00

### 1939-48 V8

81A-6330-AS SET STD. 85.00

81A-6330-CS SET .010 110.00

81A-6330-FS SET .020 110.00

81A-6330-NS SET .030+ 125.00

### 1942-47 6 CYLINDER G SERIES

1GA-6330-A SET STD. 129.95

1GA-5330-F SET .010 INQUIRE

1GA-6330-G SET .020 129.95

1GA-6330-H SET .030 INQUIRE

### 1947-51 6 CYLINDER H SERIES

7HA-6330-F SET STD. 145.00

7HA-6330-H SET .010 145.00

7HA-6330-J SET .020 145.00

7HA-6330-K SET .030 145.00



**REAR MAIN BEARING OIL SEAL**

- 1936-42, UPPER  
78-6335 EACH 17.50
- 1939-48, UPPER  
91A-6335 EACH 22.50
- 1936-42, LOWER  
78-6336 EACH 17.50
- 1942-48, LOWER  
19B-6336 EACH 35.00

**OTHERS AVAILABLE - INQUIRE**



**MAIN BEARING BOLT NUT**

- 932-48  
B-6348 EACH .95

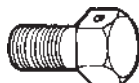

**FLYWHEEL BOLT**

- 1932-48  
B-6376 SET 1.50



**FLYWHEEL RING GEAR**

- 1932-48 V8; 32-34 4 CYL.  
B-6384 EACH 34.95
- 1941-47, G SERIES 6 CYL. (112 TEETH)  
2GA-6384 EACH 85.00
- 1941-47, H SERIES 6 CYL. (114 TEETH)  
8HA-6384 EACH 85.00
- 1948-53, 8 CYLINDER (112 TEETH)  
8BA-6384 EACH 42.95

**VALVE TRAIN**



**VALVE GUIDE TOOL**

- ORIGINAL TYPE GUIDE REMOVING TOOL  
1932-48 V8  
B-6500-VGBAR EACH 57.50

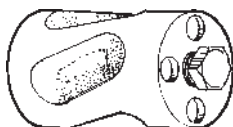

**ADJUSTABLE TAPPETS - U.S.A.**

- 1932-48, 6 & V8  
91A-6500-AJ EACH 15.00

**ADJUSTABLE TAPPET WRENCH**

- 91A-6500-AJW PAIR 15.00

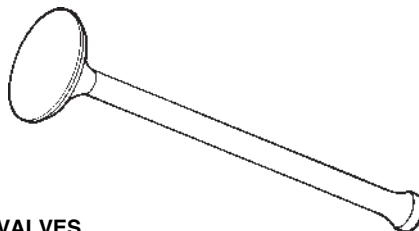

**VALVES**

- 1932-48 V8 INTAKE & EXHAUST  
11T-6505 EACH 17.00
- 1947-53 V8 (STRAIGHT SHAFT)  
8BA-6505 EACH 12.00

**EXHAUST VALVE**

- 1941-47, G SERIES 6 CYL.  
1GA-6505 EACH 15.00
- 1947-48, H SERIES 6 CYL.  
7HA-6505-A EACH 10.00

**INTAKE VALVE**

- 1941-47, G TYPE 6 CYL.  
1GA-6507 EACH 7.50
- 1947-48, H SERIES 6 CYL.  
7HA-6507 EACH 25.00

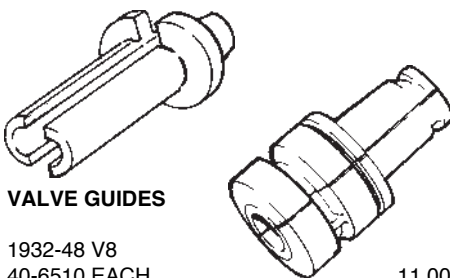

**VALVE GUIDES**

- 1932-48 V8  
40-6510 EACH 11.00
- 1947-53 SOLID (USED WITH 8BA-6505)  
8BA-6510 EACH 7.00
- 1941-47 EXHAUST; G SERIES (SPLIT)  
6 CYLINDER  
1GA-6510 EACH 10.00
- 1947-48 H SERIES 6 CYL.(SOLID)  
7HA-6510-A EACH 11.00
- 1941-47 INTAKE; G SERIES 6 CYL.  
1GA-6511 EACH 10.00



**VALVE GUIDE RETAINER**

- 1932-48 V8; 41-47 6 CYL.  
40-6512 EACH 1.00

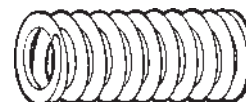

**VALVE SPRING**

- 1932-48 V8; 41-47 6 CYL.  
78-6513 EACH 3.50



**VALVE SPRING RETAINER**

- 1932-48 V8; 41-47 6 CYL.  
40-6514 EACH 1.50

**1947-53 V8 (USE WITH 8BA-6505)**

- 7HA-6518 PAIR 1.00
- 8BA-6514 EACH 2.00
- BOTH NEEDED FOR STRAIGHT  
STEM VALVE

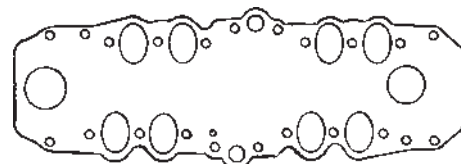

**INTAKE MANIFOLD GASKET**

- 1932-48 V8  
40-6521 EACH 14.95

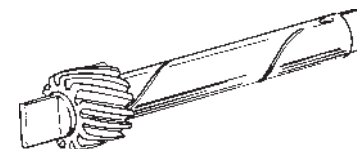

**OIL PUMP DRIVE GEAR**

- 1932-34 4 CYLINDER  
B-6551-C (1 PC., U.S.A.) EACH 24.95
- B-6551-F (2 PC.) SET DISCONTINUED



**OIL PUMP GEAR SLEEVE (4 CYL)**

- B-6561 EACH 3.95



**VALVE GUIDE SEAL**

- 1948-53 V8  
8BA-6571 EACH .65

**USE OUR 800 NUMBER OR  
FAX NUMBER FOR  
PLACING YOUR ORDER!**

# ENGINE (CONT'D.)

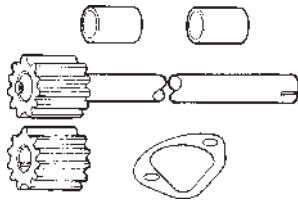

**OIL PUMP REBUILDING KIT**  
1932-34 4 CYLINDER  
B-6600-RK KIT 21.00

1932-42 V8 (EXCEPT 60 H.P.)  
18-6600-RK KIT 49.95

1939-48  
41A-6600-RK EACH 49.95

1941-47 6 CYL. (2 GEARS & BUSHING)  
1GA-6600-RKT KIT INQUIRE

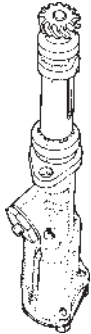

**OIL PUMP ASSEMBLY**  
1935-42 V8; LONG BODY, 50 LB. PRESS.  
REBUILT  
68-6600-R EACH 139.95

1935-48 V8; LONG BODY, 80 LB. PRESS.  
REBUILT  
41A-6600-R EACH 139.95

1932-48 NEW; SHORT BODY, LESS  
SCREEN. U.S.A. PUMP  
59A-6600 EACH 95.00



**OIL PUMP PICKUP TUBE & COVER**  
1932-48 V8 FOR NEW SHORT BODY 59A  
OIL PUMP  
8RT-6615 EACH 29.95



**OIL PUMP SCREEN COVER**  
1936-42 V8  
01A-6615 EACH 5.95

**OIL PUMP IDLER GEAR (IN BLOCK)**  
1932-48 V8  
18-6655-A EACH 14.50

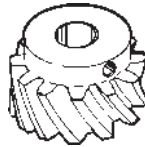

**OIL PUMP UPPER GEAR**  
1932-48 V8  
18-6652 EACH 7.95

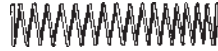

**OIL PUMP RELIEF VALVE SPRING**  
1932-42  
01A-6654 EACH 1.50



**TIMING GEAR COVER PACKING**  
1932-48 ALL  
ORIGINAL TYPE - BRAIDED  
B-6700 EACH 7.50  
NEOPRENE - IMPROVED SEAL  
B-6700-B EACH 33.00



**OIL PAN DRAIN PLUG**  
1932-38  
B-6730 EACH 3.00

1939-48  
52-6730-A EACH 10.00



**OIL FILTER ELEMENT**  
1940-48 ALL  
7HA-6731 EACH 9.25



**OIL DRAIN PLUG GASKET**  
1932-38  
B-6734 EACH .95

1939-48  
52-6734-A EACH 1.50



**DIP STICK**  
**1933-38**  
40-6750 EACH INQUIRE  
1935-48  
48-6750 EACH 17.50

**DIP STICK TUBE**  
1935-48 V8  
48-6754-B EACH 9.95

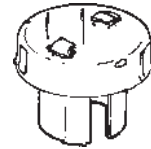

**OIL FILLER CAP**  
1932-34 V8  
18-6766 EACH INQUIRE  
1932-34 4 CYLINDER  
B-6766 EACH N.O.S. 75.00

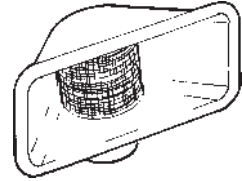

**OIL FILLER CAP**  
1935, SCOOP STYLE  
48-6766-A EACH INQUIRE

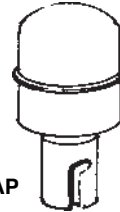

**OIL FILLER CAP**  
1935-48  
48-6766-B EACH 20.00

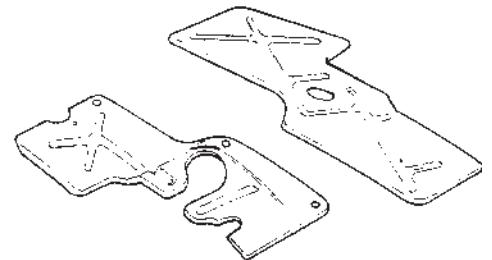

**V8 ENGINE SPLASH APRONS**  
1933-34 V8  
40-6775/76 SET INQUIRE

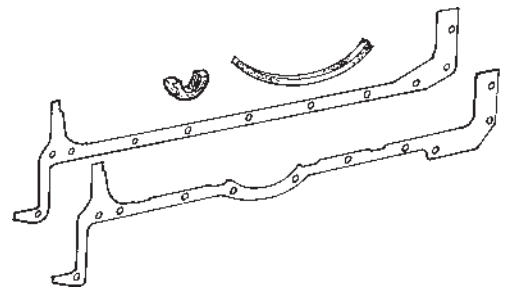

**OIL PAN GASKET SET**  
1932-34 4 CYLINDER  
B-6781 SET 14.95

1932-34 V8  
18-6781 SET 18.50

1935-48 V8  
48-6781 SET 18.50

1941-47 G SERIES 6 CYLINDER  
1GA-6781 SET 20.00

1947-48 H SERIES 6 CYLINDER  
7HA-6781 SET 20.00

# TRANSMISSION

## TRANSMISSION REPAIR MANUAL

1932-47  
TRANSMISSIONS, CLUTCHES,  
OVERDRIVES, & POWER TAKE-OFFS  
95-3697 AF (80 PAGES) EACH 8.00

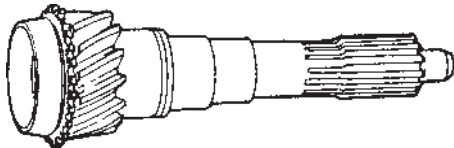

### MAIN DRIVE GEAR - U.S.A

1932-39, 16 TEETH  
48-7017 EACH 125.00

1936-40, 14 TEETH  
67-7017 EACH 100.00

1939-48, 16 TEETH  
81A-7017 EACH 150.00

1939-48, 15 TEETH  
022A-7017 EACH 150.00

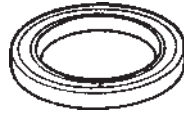

### MAIN DRIVE OIL SEAL

1932-36 CORK  
40-7052 EACH 5.00

1932-48 SEAL  
78-7052 EACH 6.50

### TAILSHAFT OIL SEAL

1942-47 COMMERCIAL  
21C-7052-A EACH 9.50

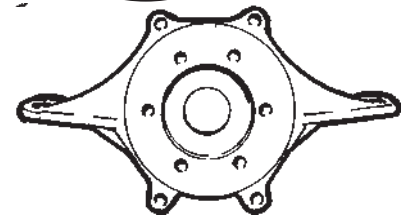

### MAIN SHAFT BEARING RETAINER

1937-40 PASSENGER, 37-41 COMM  
78-7085-B EACH 50.00

1938-39 COMMERCIAL  
99A-7085 EACH 39.95

1942-48 PASSENGER  
21A-7085 EACH 34.95

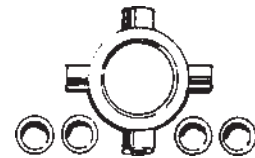

### UNIVERSAL JOINT CROSS KIT

1932-48 PASSENGER; 32-41 COMM.  
B-7084 EACH 67.50

1942-48 COMMERCIAL  
21C-7039 KIT 25.50

1940-48 1 TON TRUCK  
01Y-7039 KIT 24.95

### OTHERS AVAILABLE - INQUIRE

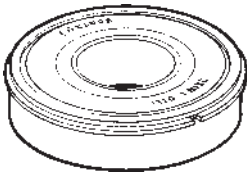

### MAIN DRIVE BALL BEARING, U.S.A.

1932-48  
B-7025-TIM EACH 54.50  
B-7025-E EACH 27.50



### MAIN DRIVE OIL SLINGER

1932-48  
B-7040 EACH 2.00

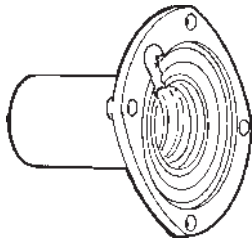

### TRANSMISSION FRONT BEARING RETAINER

1932-48  
78-7050 EACH 48.50

### MAIN SHAFT PILOT BEARING SPACER

1932-48  
B-7063 EACH 1.25

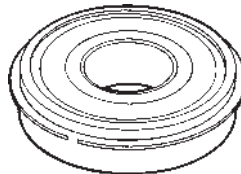

### MAIN SHAFT BALL BEARING, U.S.A.

1932-48  
B-7065-TIM EACH 52.50  
B-7065-E EACH 27.50



### SECOND GEAR THRUST WASHER

1932-39  
B-7069 EACH 4.50



### MAIN SHAFT OIL BAFFLE

1932-35  
B-7080 EACH 2.50

1936-48  
68-7080 EACH 3.00

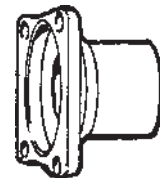

### UNIVERSAL JOINT FLANGE

1942-47 COMMERCIAL 2 7/16" LONG  
01T-7089 EACH 39.95

1942-47 COMMERCIAL 4 SPEED  
01Y-7089 EACH 34.95

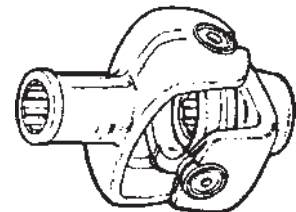

### UNIVERSAL JOINT

1928-48  
B-7090 EACH 75.00  
USED 125.00  
REPRODUCTION 200.00  
N.O.S.



### TRANSMISSION MAIN SHAFT

MANY VARIATIONS - INQUIRE AS TO NEED  
B-7061 EACH INQUIRE

**V8-60 AND ALL TRUCK  
4 SPEED GEARS IN  
STOCK**

**ALL TRUCK AND V8-60  
U-JOINTS AVAILABLE**

# TRANSMISSION

(CONT'D.)

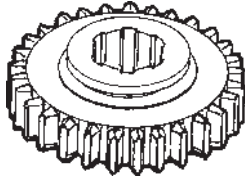

**LOW & REVERSE SLIDING GEAR - U.S.A.**

- 1932-35, 29 SPUR TEETH  
B-7100 EACH 125.00
- 1936-40, 29 SPUR TEETH  
67-7100 EACH 95.00
- 1936-48, 29 HELICAL TEETH  
01A-7100 EACH INQUIRE

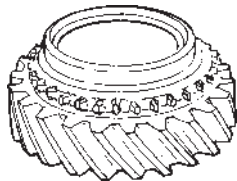

**SECOND GEAR - U.S.A.**

- 1932-39  
B-7103 EACH 99.95
- 1939-48 w/ GROOVE  
81A-7102 EACH 225.00
- 1939-48  
51A-7102 EACH 225.00

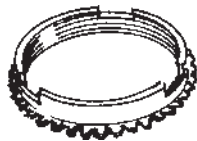

**SYNCHRONIZER BRASS RING**

- 1939-48  
81A-7107 EACH 15.00

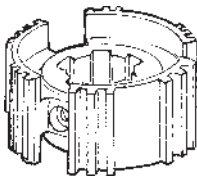

**SYNCHRONIZER HUB**

- 1932-39  
B-7108 EACH 125.00

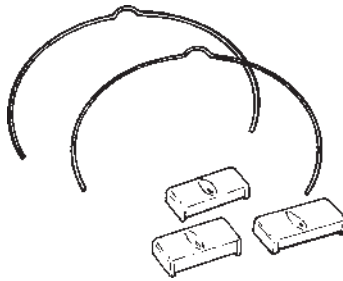

**SYNCHRONIZER CLIP & SPRING KIT**

- 1942-48  
51A-7109-S KIT 5.50



**CLUSTER GEAR SHAFT**

- 1932-48  
B-7111 EACH 11.00

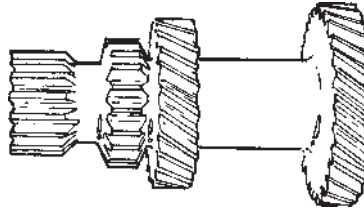

**CLUSTER GEAR - U.S.A.**

- 1932-34  
28 & 24 HELICAL, 18 & 15 SPUR TEETH  
B-7113 EACH 300.00
- 1932-35  
28 & 24 HELICAL, 18 & 15 SPUR TEETH  
48-7113 EACH 155.00
- 1936-41  
29 & 24 HELICAL, 17 & 15 SPUR TEETH  
67-7113 EACH 155.00
- 1936-48  
28, 24, 18, 14 HELICAL TEETH, 4 SLOTS  
68-7113 EACH INQUIRE
- 1939-48  
29, 24, 18, 14 HELICAL TEETH, 4 SLOTS  
022A-7113 EACH INQUIRE
- 1939-48  
29, 24, 18, 14 HELICAL TEETH, 2 LUGS  
21C-7113 EACH INQUIRE
- 1939-48  
28, 24, 18, 14 HELICAL TEETH, 2 LUGS  
8M-7113 EACH INQUIRE

**4 SPEED TRUCK GEARS  
IN STOCK, PLEASE ASK!**

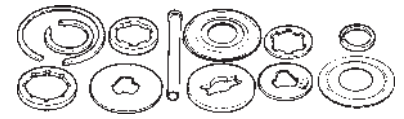

**TRANSMISSION SMALL PARTS KIT  
3 SPEED**

- 1936-39  
68-7113-RK KIT INQUIRE
- 1940-48  
022A-7113-RK KIT INQUIRE



**CLUSTER GEAR BEARINGS, MAIN SHAFT  
PILOT BEARING**

- 1932-48  
SHORT (2 REQ'D)  
B-7118 EACH 7.50
- LONG (1 REQ'D)  
B-7121 EACH 6.50

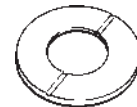

**CLUSTER GEAR FRONT THRUST WASHER**

- 1936-48  
B-7119 EACH 8.50

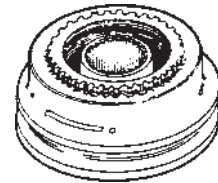

**SYNCHRONIZER ASSEMBLY-U.S.A.**

- 1940-48  
01A-7124 EACH 189.00



**CLUSTER GEAR REAR THRUST PLATE**

- 1936, USE WITH 48-7113 4 OR 5 OUTER  
68-7129-A EACH 4.75
- 1935-48, 4 SLOTS  
68-7129-B EACH 18.50
- 1936-48, 2 LUGS  
8M-7129-A EACH 17.00



**REVERSE IDLER GEAR SHAFT**

1932-48  
B-7140 EACH

16.00



**GEAR SHIFT LEVER RUBBER INSULATOR**

1940-48 PASSENGER (COLUMN SHIFT)  
01A-7246-B EACH 5.00



1941 ALL  
11A-7213 EACH

8.00

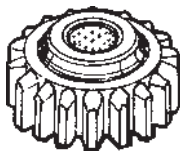

**REVERSE IDLER GEAR - U.S.A.**

1932-35, SPUR GEAR  
B-7141 EACH

39.95



**SHIFT LEVER OIL SEAL**  
1940-48 PASSENGER (COLUMN SHIFT)  
01A-7288 EACH (2 REQ'D) 7.50



1942 SPECIAL (MAROON)  
21A-7213-A EACH

8.00

1936-48, HELICAL GEAR  
68-7141 EACH

78.50

**GEAR SHIFT KNOBS**



1932-36, BLACK  
A-7213-A EACH 8.00



1946 DELUXE  
51A-7213-A EACH 8.00

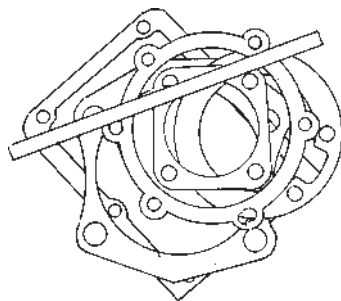

**TRANSMISSION & U-JOINT GASKET SET**

1932-48  
B-7153 SET 10.00



1946 SUPER DELUXE  
51A-7213-B EACH 8.00

1932-48, 4 SPEED (TRUCK)  
BB-7153 SET 14.00

1937-38, BROWN  
78-7213 EACH 8.00

1946 CONVERTIBLE, WAGON & SPORTS-  
MAN; 1947-48 ALL  
51A-7213-C 8.00

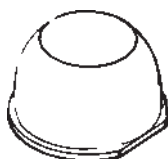

**GEAR SHIFT HOUSING CAP**

1932-39  
BB-7220 EACH 4.50



1936-47 PICKUP, BLACK  
91C-7213 EACH 8.00

**TRUCK 4 SPEED TRANSMISSION KNOB**  
1929-52  
BB-7213 EACH 12.50



**ONYX GEAR SHIFT KNOB**  
-O= ROUND -M=MUSHROOM

**SHIFT TUBE SPRING**  
1940-48, PASSENGER (COLUMN SHIFT)  
01A-7227 EACH 3.00



1939 FORD & MERCURY  
91A-7213 EACH 8.00

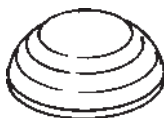

BLUE & WHITE SWIRL  
A-7213-BO EACH 25.00  
A-7213-BOM EACH 25.00



GREEN & WHITE SWIRL  
A-7213-GO EACH 25.00  
A-7213-GOM EACH 25.00

1940 STANDARD  
01A-7213-A EACH 8.00

RED & WHITE SWIRL  
A-7213-RO EACH 25.00  
A-7213-ROM EACH 25.00

1940 DELUXE  
01A-7213-D 8.00

MUAVE & WHITE SWIRL  
A-7213-KO EACH 25.00  
A-7213-KOM EACH 25.00

# TRANSMISSION

(CONT'D.)

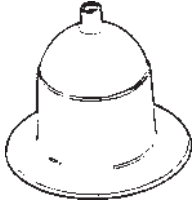

**GEAR SHIFT BOOT**

MOULDED RUBBER TO ORIGINAL SPECIFICATIONS.

1932-36, BLACK  
99A-7242-b EACH 20.00

1932-39, TAUPE (TAN)  
99A-7242-t EACH 25.00

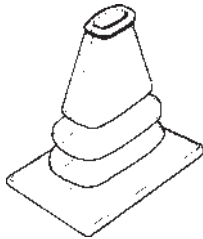

**EMERGENCY BRAKE HANDLE FLOOR BOOT**

1932-39 COMMERCIAL & SOME PASS.  
BLACK  
A-7000-BB EACH 3.95  
TAUPE  
B-7000-T EACH 5.00



**1940-48 PASSENGER GEAR SHIFT N.O.S.**

**SHIFTER TUBE LEVER (2ND & 3RD)**  
1940-48 PASSENGER  
01A-7302 EACH 29.95

**SHIFTER TUBE LEVER (1ST & REVERSE)**  
1940-48 PASSENGER  
01A-7303 EACH 29.95

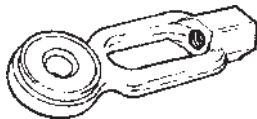

**COLUMN SHIFT ROD CLEVIS - N.O.S.**  
1940-48 PASSENGER  
01A-7329 EACH 18.00



**GEAR SHIFT TUBE LEVER PIN**  
1940-48 PASSENGER  
01A-7337 EACH 1.95

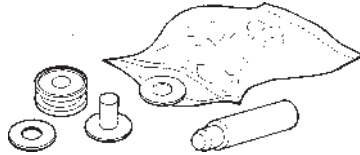

**SHIFTING LINKAGE REPAIR KIT**

ALL THE BRASS & RUBBER BUSHINGS NEEDED TO REBUILD SHIFTING ARMS.

1940-48 ONE KIT REQUIRED  
01A-7354-RK KIT 30.00



**CLUTCH & BRAKE PEDAL SHAFT**

1932-34 PASSENGER, COMM., 32-39 TRUCK  
B-7506 EACH 27.00

1935-36 PASSENGER  
48-7506 EACH 30.00

1939 PASSENGER  
91A-7506 EACH 15.00

1940-48 PASSENGER  
01A-7506 EACH 15.00

1940-48 COMMERCIAL  
01T-7506 EACH 24.95

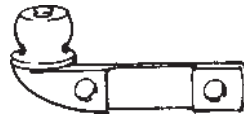

**CLUTCH EQUALIZER BALL & BRACKET**

1940-48 PASSENGER & COMMERCIAL  
01A-7507 EACH 33.00

1940-48 3/4 TON & 1 TON  
01Y-7507 EACH 29.95

1940-47 2 TON TRUCK  
01T-7507 EACH 29.95



**CLUTCH RELEASE SHAFT BUSHING**

1928-34 PASSENGER & COMMERCIAL  
B-7508 EACH 7.00

1932-48 PASSENGER & COMMERCIAL  
40-7508 EACH (THIN WALL) 4.50

1941-48 PASSENGER & COMMERCIAL  
51A-7508 EACH (THICK WALL) 8.00



**CLUTCH RELEASE EQUALIZER SHAFT**  
1940 PASSENGER, '40-41 COMMERCIAL  
01A-7503 EACH 125.00  
1941-48 PASSENGER  
51A-7503 EACH INQUIRE



**CLUTCH RELEASE SHAFT**

1932-39, ALL  
B-7510 EACH 33.00

1940-48, ALL  
01A-7510 EACH 50.00

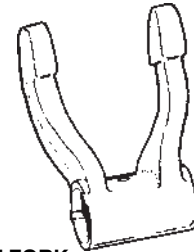

**THROWOUT FORK**

1932-48 PASSENGER, 32-47 COMM.  
48-7515 EACH 22.50



**CLUTCH BALL SPLIT BUSHING**

1940-48 PASSENGER, 40-47 COMM.  
01A-7517 PAIR 8.00



**CLUTCH PEDAL ROD, 4"**

1935-39 PASSENGER & COMM., 32-34 TRUCK  
48-7521 EACH 12.95

**OTHERS AVAILABLE - INQUIRE**



**CLUTCH PEDAL RETRACTING SPRING**

1933-34 PASSENGER & COMMERCIAL  
40-7523 EACH 4.50

1935-36 PASSENGER & COMMERCIAL  
48-7523 EACH 4.50

1937-38 PASSENGER & COMMERCIAL  
78-7523 EACH 4.50

1939 PASSENGER & COMMERCIAL  
91A-7523 EACH 6.00

1940 PASSENGER, 40-41 PICKUP  
01A-7523 EACH 5.00

1942-47 1/2 TON COMM.  
01T-7523 EACH 4.50

1941-48 PASSENGER  
11A-7523 EACH 4.50



**CLUTCH & BRAKE PEDAL BUSHING**

1932-34 PASSENGER & COMMERCIAL  
32-47 TRUCK  
1.78" LONG  
B-7526 EACH 6.00

1935-38 PASSENGER & COMMERCIAL  
1.80 LONG  
48-7526 EACH 3.50

1935-38 PASSENGER, 38-47 COE  
LONG STEEL BUSHING  
48-2470 EACH 50.00

1939 PASSENGER & COMMERCIAL  
LARGE BUSHING *NEW!*  
91A-7526 EACH 35.00

1940-48 PASSENGER  
(2 REQ'D PER PEDAL)  
01A-7526 EACH 2.50

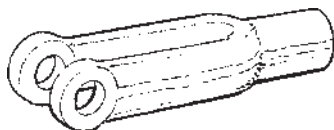

**CLUTCH ADJUSTING ROD CLEVIS**

1932-48, ALL  
B-7532 EACH 12.00



**CLUTCH & BRAKE PEDAL PIN**

1932-48, ALL  
B-7533 EACH 2.75

1940-41, ALL  
01A-7533 EACH 2.50



**CLUTCH RELEASE SHAFT WASHER**

1940-48 PASSENGER, 40-47 COMM. &  
TRUCK (RUBBER SEAL)  
01A-7539 EACH 1.25



**CLUTCH RELEASE SHAFT SPRING**

1940-48 PASSENGER, 40-47 COMM. &  
TRUCK  
01A-7545 EACH 2.25

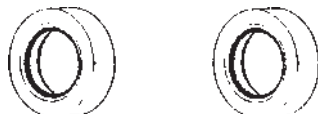

**TRANSMISSION SHIFT ROD SEALS**

1940-48  
01A-7288 EACH (2 REQ'D.) 7.50

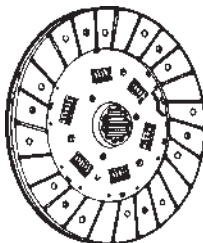

**CLUTCH DISC**

1932-41, 9" DIAMETER  
B-7550 EACH *NEW* 65.00

1942-48, 10" DIAMETER  
51A-7550 EACH *NEW* 65.00

1935-48 TRUCK WITH 11" CLUTCH  
81T 7550 EACH *NEW* 65.00

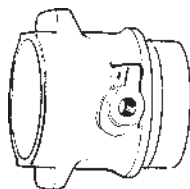

**THROWOUT BEARING HUB**

1932-34 PASSENGER & COMMERCIAL  
09B-7561 SET 19.95

1935-48 PASSENGER & COMMERCIAL  
48-7561 SET 21.00



**THROWOUT BEARING SPRING**

1932-34 PASSENGER & COMMERCIAL  
B-7562 EACH 2.00

1935-48 PASSENGER, 32-47 COMM. &  
TRUCK  
48-7562 EACH 2.00

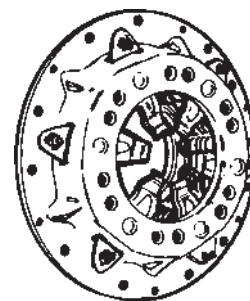

**CLUTCH PRESSURE-PLATE ASSEMBLY (REBUILT)**

1932-34 PASSENGER & COMM., 9"  
BB-7563 EACH 110.00  
EXCHANGE OR 35.00 CORE CHARGE

1935-40 PASSENGER & COMM., 9"  
09A-7563 EACH \* 95.00

1941-48 PASSENGER & COMM., 10"  
19A-7563 EACH \* 95.00

1935-48 TRUCK WITH 4 SPD. TRANS., 11"  
51-7563 EACH \* 125.00  
\*EXCHANGE OR 25.00 CORE CHARGE

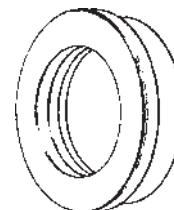

**THROWOUT BEARING**

1932-48 PASSENGER, 32-47 COMM. &  
TRUCK  
78-7580 EACH 27.00

1935-48 PASSENGER & COMMERCIAL  
WITH HUB  
78-7580-C EACH 45.00

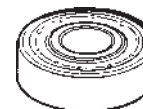

**PILOT BEARING**

1928-48  
B-7600-A EACH 5.95

1928-48 (BRONZE BUSHING)  
70-7600-A EACH 5.95

**USE OUR 800 NUMBER OR  
FAX NUMBER FOR  
PLACING YOUR ORDER!**



# FLATHEAD SPEED EQUIPMENT

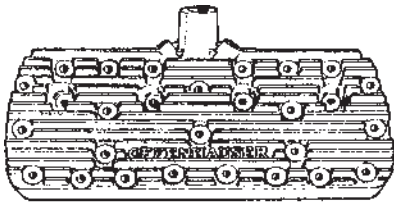

## OFFENHAUSER ALUMINUM HEADS

VARIOUS COMPRESSION RATIOS AVAILABLE IN THESE QUALITY HEADS. PLEASE INQUIRE.

1939-48 221+ CI FLATHEAD HEADS  
91A-6050-AS PAIR 649.99

V-8 60 136 CI FLATHEAD HEADS  
52-6050-AS PAIR 979.00

ADD 160.00 FOR POLISHING

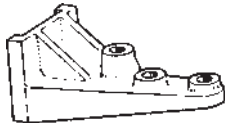

## HEAD-MOUNT GENERATOR BRACKET

1937-48  
LEFT HAND MOUNT 48.50  
78-6520-LBKT EACH  
RIGHT HAND MOUNT 48.50  
78-6520-RBKT EACH

1949-53 AVAILABLE. PLEASE INQUIRE



## OFFENHAUSER ALUMINUM INTAKE MANIFOLDS

**DUAL**  
1932-48 REGULAR DUAL MANIFOLD  
18-6520-A2S EACH 245.00

1932-41 SUPER DUAL MANIFOLD  
(INCLUDES GENERATOR BRACKET)  
18-6520-B2S EACH 349.00

1942-48 SUPER DUAL MANIFOLD  
INCLUDES GENERATOR & FANBRACKETS  
21A-6520-C2S EACH 379.00

**TRIPLE**  
1932-41 TRIPLE MANIFOLD  
(INCLUDES GENERATOR BRACKET)  
18-6520-A3S EACH 299.00

1942-48 TRIPLE MANIFOLD  
INCLUDES GENERATOR & FANBRACKETS  
21A-6520-C3S EACH 329.00

**SINGLE 4-THROAT**  
1932-48 4-THROAT MANIFOLD  
18-6520-A4S EACH 275.00



## DUAL POINT IGNITION

1932-48 FLATHEAD  
6 VOLT  
3 BOLT MOUNTING 78-12127-M6 EACH INQUIRE  
2 BOLT MOUNTING 21A-12127-M6 EACH INQUIRE  
12 VOLT

3 BOLT MOUNTING 78-12127-M12 EACH INQUIRE  
2 BOLT MOUNTING 21A-12127-M12 EACH INQUIRE

## ELECTRONIC IGNITION - 12 VOLT

1932-48 FLATHEAD  
SELF CONTAINED - NO MDS BOX NEEDED  
3 BOLT MOUNTING 78-12127-E EACH INQUIRE  
2 BOLT MOUNTING 21A-12127-E EACH INQUIRE



## BLOCK-OFF PLATE

1934-48 FUEL PUMP BLOCK-OFF PLATE  
11A-9375-AS EACH 24.95

## FUEL BLOCK

EQUILIZES FUEL PRESSURE TO ALL CARBURETORS. MOUNTS ON FIREWALL.

18-9350-AS EACH 59.99

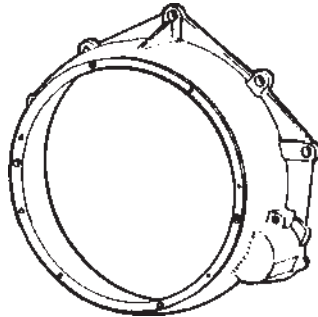

## ENGINE ADAPTERS

1932-48 FORD TRANSMISSION TO CHEVROLET ENGINE 1955-56 V-8  
18-0307-AS EACH 279.00

## CHEVROLET TRANSMISSION ADAPTERS

1932-48 FORD, 39-50 MERC. TO CHEVROLET 3 OR 4 SPEED TRANSMISSION  
18-5174-AS EACH 375.00

1932-48 FORD TO CHEVROLET 3 OR 4 SPEED TRANSMISSION. FOR USE WITH EARLY FORD CLUTCH RELEASE SHAFT & THROWOUT BEARING.  
18-5272-AS EACH 375.00

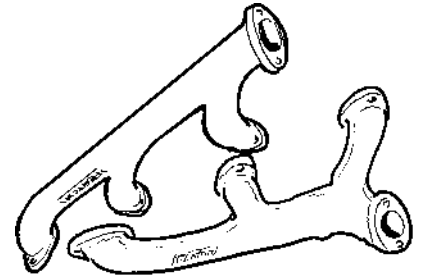

## FENTON HEADERS

1935-48 V8  
NEW CASTINGS  
F-9430/1 PAIR INQUIRE



## BEEHIVE OIL FILTER

PAINTED  
18-18658-A EACH INQUIRE

CHROME MOUNTING BRACKET  
18-18665 EACH 39.99

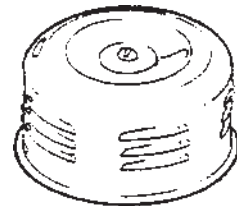

## '50's STYLE AIR CLEANERS

CHROME PLATED  
PLAIN  
B-9600-C EACH 15.00\*

LOUVERED  
B-9600-CV EACH 15.00\*  
\*SPECIAL - 3 AIR CLEANERS 35.00

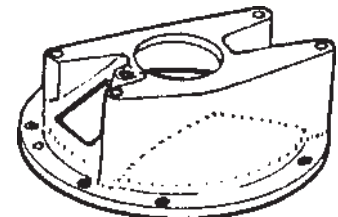

## FLATHEAD ENGINE TO C-4 AUTOMATIC TRANSMISSION

FITS 1932-53 FORD & MERCURY  
THIS KIT INCLUDES ALL THE NECESSARY PARTS TO USE A C-4 AUTOMATIC TRANSMISSION WITH YOUR FLATHEAD ENGINE.  
18-6392-C4 KIT 525.00

CALL: 1-800-532-1932

COMING SOON !!!- TRY OUR  
WEBSITE AT: [allfordparts.com](http://allfordparts.com)  
E-mail: [allford@jps.net](mailto:allford@jps.net)



**ALL FORD PARTS**

**1600 DELL AVENUE, SUITE A, CAMPBELL, CALIFORNIA 95008**

**408-378-1935 • 1-800-532-1932 • FAX: 408-866-1934**